



## PLANIFIX PRO 55 USE AND MAINTENANCE HANDBOOK

This handbook contains important information for the safe use and operation of this machine. Failure to read the handbook prior to using, adjusting or carrying out maintenance on the machine could lead to personal injury and/or damage. Operators must be familiar with all instructions before using the machine. Keep this handbook for future reference. For replacements, write to:

**Künzle & Tasin S.p.A.**

Sales Office and Plant: Via Cajkovskij, 14 20092 Cinisello Balsamo - Milan - Italy

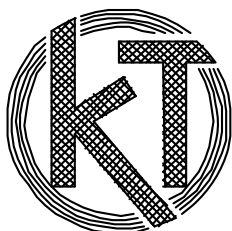
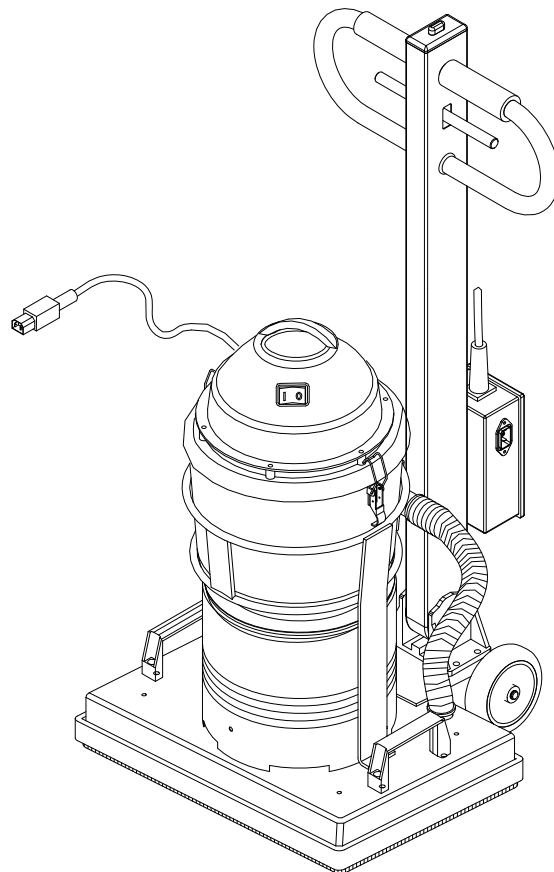

**KÜNZLE & TASIN**  
*Smerigliatrici e levigatrici dal 1946*

DIREZIONE COMMERCIALE E STABILIMENTO

Via CAJKOVSKIJ,14 - 20092 CINISELLO BALSAMO - MILANO - ITALIA

TEL. 02 / 66040930 r.a. - FAX 02 / 66013445



## CONTENTS

|   |            |
|---|------------|
| <b>ICONS DISPLAYED ON THE MACHINE</b> .....               | <b>3</b>   |
| <b>STORAGE</b> .....                                      | <b>4</b>   |
| <b>MACHINE TRANSPORT AND HANDLING</b> .....               | <b>4</b>   |
| HANDLING BY ONE PERSON .....                              | 4          |
| HANDLING BY TWO PERSONS .....                             | 4          |
| <b>COMMISSIONING</b> .....                                | <b>5</b>   |
| ASSEMBLY INSTRUCTIONS .....                               | 5          |
| <b>CABLES, EXTENSION LEADS AND PLUGS</b> .....            | <b>6</b>   |
| <b>REMOVING SAWDUST</b> .....                             | <b>6</b>   |
| <b>PREVENTIVE SAFETY RECOMMENDATIONS</b> .....            | <b>7</b>   |
| PERSONAL PROTECTION .....                                 | 7          |
| RESPECT OF SAFETY DEVICES AND WARNINGS .....              | 7          |
| OPERATING INSTRUCTIONS .....                              | 8          |
| <b>MACHINE SPECIFICATIONS</b> .....                       | <b>9</b>   |
| <b>STARTING AND STOPPING THE MACHINE</b> .....            | <b>9</b>   |
| FIG. 2 .....  | 10         |
| E – GRIP .....  | 10         |
| <b>MACHINE ADJUSTMENT</b> .....                           | <b>10</b>  |
| ADJUSTING GRIP HEIGHT .....                               | 10         |
| <b>FITTING THE ABRASIVE</b> .....                         | <b>10</b>  |
| <b>PERIODIC MAINTENANCE</b> .....                         | <b>11</b>  |
| SANDING CHAMBER ( <i>USER MAINTENANCE</i> ) .....         | 11         |
| SANDING PLATE ( <i>USER MAINTENANCE</i> ) .....           | 11         |
| WHEELS ( <i>USER MAINTENANCE</i> ) .....                  | 11         |
| DUST SUCTION GROUP ( <i>USER MAINTENANCE</i> ) .....      | 11         |
| BEARINGS ( <i>SERVICE CENTRE ONLY MAINTENANCE</i> ) ..... | 11         |
| <b>REPLACEMENT PARTS</b> .....                            | <b>11</b>  |
| <b>TROUBLESHOOTING (FOR USER)</b> .....                   | <b>12</b>  |
| FAULT .....   | 12         |
| CAUSE .....   | 132        |
| REMEDY .....  | 132        |
| <b>CE CONFORMITY DECLARATION</b> .....                    | <b>143</b> |



## ICONS DISPLAYED ON THE MACHINE

|   |  |
|---|--|
|    | <b>READ USE AND MAINTENANCE INSTRUCTIONS BEFORE USING THE MACHINE.</b> |
|    | <b>NOISE HAZARD. USE EAR PROTECTION.</b>                               |
|    | <b>DUST HAZARD. USE FACE MASK.</b>                                     |
|    | <b>DANGER. VOLTAGE PRESENT.</b>  |
|  | <b>DANGER. MOVING PARTS.</b>   |

|                 |       |  |
|-----------------|-------|--|
| <b>DANGER:</b>  | means | Serious injury or death to operators or others if <b>DANGER</b> signs on the machine or in the handbook are ignored or not respected. Read and follow all <b>DANGER</b> warnings on the machine or in the handbook |
| <b>WARNING:</b> | means | Injury to the operator or others if <b>WARNING</b> signs on the machine or in the handbook are ignored or not respected. Read and follow all <b>WARNINGS</b> on the machine or in the handbook                     |
| <b>CAUTION:</b> | means | Injury to the operator or others if <b>CAUTION</b> signs on the machine or in the handbook are ignored or not respected. Read and follow all <b>CAUTION</b> warnings on the machine or in the handbook             |

**DANGER:**  
Failure to read the **PLANIFIX PRO 55** handbook before using, adjusting or carrying out maintenance on the machine could result in personal injury or damage. The operator must be familiar with the machine before using it.



## **STORAGE**

Store the machine without removing its original packaging. Do not stack more than two high.  
Store the machine in a dry place to prevent damage.  
Storage temperature -20°C to 50°C.

## **MACHINE TRANSPORT AND HANDLING**

**WARNING:**                    **The machine is heavy. Do not attempt to lift it alone.**

### **HANDLING BY ONE PERSON**

To move the machine, lock the handle in the vertical position. Use the handle as a lever and the wheels as pivot to lift the base. In this position the machine can be moved easily.

### **HANDLING BY TWO PERSONS**

With two people to move the machine, lift it by the handles on the sides of the base.

## COMMISSIONING

### ASSEMBLY INSTRUCTIONS

To assemble the machine after transport, proceed as follows:

1. Position the handle as shown in the drawing and connect it to the base by inserting the fork and fastening it by means of the handle locking group A
2. Connect plug B from the motor to the socket on the lower part of the box.
3. Connect plug C from the suction group to auxiliary socket D on the side of the box.

**DANGER:**

Using the machine when not correctly assembled could result in personal injury and/or damage. Never use the machine if not fully assembled. Check all fastenings for tightness. Adjust the machine to the given specifications.

Fig. 1

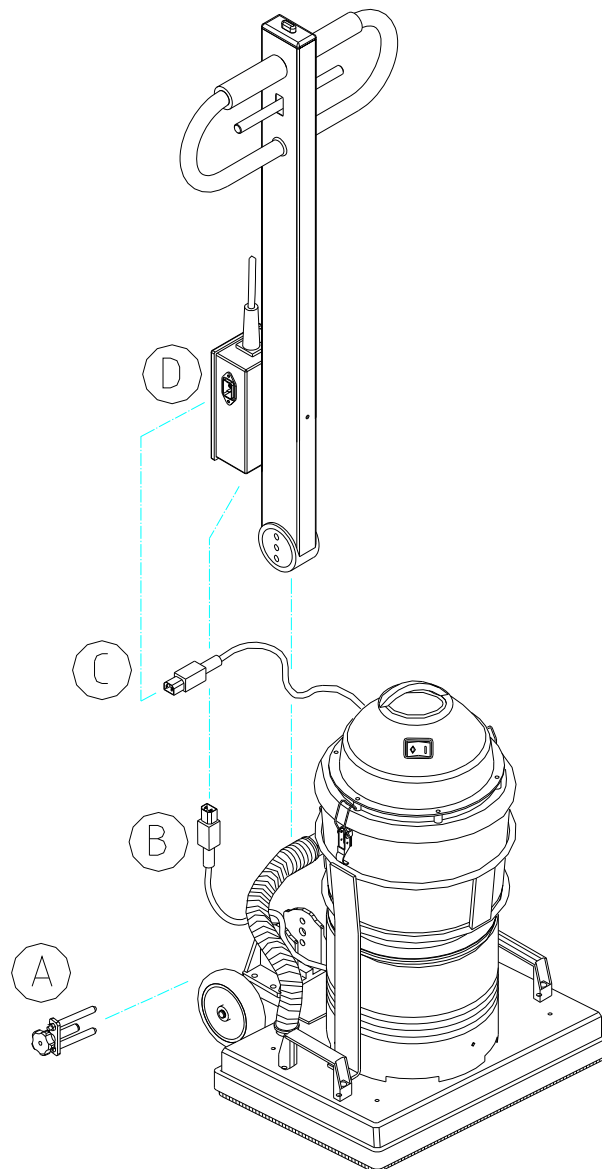



## ELECTRICAL CONNECTIONS

- CAUTION:** The machine is designed to operate at the voltage and frequency indicated on the specifications plate. Before plugging it in, check that mains voltage and frequency correspond to machine specifications.
- DANGER:** Exposing the machine to water or rain could lead to fatal electric shock. Store and use the machine in a dry place.
- DANGER:** Incorrect electrical system connections could lead to fatal electric shock. To prevent electric shock, always use mains supplies with a third earth wire. For greater protection, the mains supply should be fitted with a differential cut-out switch.
- DANGER:** Tampering with the earth plug could lead to fatal electric shock. Never cut, remove or split the earth plug. Never attempt to insert a three pin plug into any other kind of socket or connector. If the socket does not fit the plug, call a qualified electrician.
- DANGER:** Using the machine with a damaged plug or cable could lead to fatal electric shock. If cables or plugs are worn or damaged, have them replaced by a qualified electrician or authorised service personnel.

## CABLES, EXTENSION LEADS AND PLUGS

Use only 3-ply approved cables with live, neutral and earth.

Recommended maximum cable length 10 m; for lengths over **10 m** use cable with thicker section

- DANGER:** Personal injury and/or damage may result if the machine is used with excessively long or insufficiently thick cable

### ***SINGLE-PHASE 230 V~ 50 Hz MOTOR MACHINE***

For the European market the mains lead must HAR approved type **HO5VV-3x1.5 mm<sup>2</sup>** with plug type 2P+T 16A 200-250V.

**For other versions consult an authorised K&T dealer**

## REMOVING SAWDUST

- DANGER:** Sawdust is susceptible to spontaneous combustion and may cause injury or damage if ignited. It must be disposed of correctly. Always empty sawdust into metal containers and store outdoors
- DANGER:** Sawdust is susceptible to spontaneous combustion and may cause injury or damage if ignited. Empty the suction bin when it is 1/3 full. Always empty the bin after use. Never leave the machine unattended when it contains sawdust. Never empty the contents of the bin onto a fire.



## PREVENTIVE SAFETY RECOMMENDATIONS

### PERSONAL PROTECTION

- WARNING:** Sawdust may remain suspended in air and be breathed in while using the sander. Always wear a face mask when using sanding tools.
- WARNING:** Failure to use protective clothing and personal protection (masks/goggles) when working with the sander may lead to injury to the eyes and/or body. When sanding, always wear protective clothing, goggles and dust mask.
- WARNING:** Prolonged exposure to the noise generated during sanding operations may lead to permanent ear damage. When sanding, always use ear protection.

### RESPECT OF SAFETY DEVICES AND WARNINGS

- DANGER:** Using the machine when not correctly assembled could result in personal injury and/or damage. Never use the machine if not fully assembled. Check all fastenings for tightness. Keep the machine adjusted to the given specifications.
- DANGER:** Poor ventilation in working areas may create an explosive atmosphere especially in the presence of flammable materials such as solvents, thinners, fuel, certain paints, sawdust and the like. Floor sanders may cause materials and flammable vapours to ignite. Always read the manufacturer's instructions on all chemical products used to ascertain their flammability. Keep the working area well ventilated
- DANGER:** Contact with nails while sanding may create sparks and cause an explosion or fire. Fully sink all nails before beginning to sand floor surfaces
- DANGER:** Repeated power supply cuts-out or undersized power supplies may cause fatal electric shock. Have the fuses, protection circuit or mains lead checked by a qualified electrician
- DANGER:** Maintenance and/or repairs made to a machine connected to the mains may lead to fatal electric shock. Always disconnect the power supply before carrying out any maintenance and/or repair
- DANGER:** Using the machine without an adequate earth may lead to fatal electric shock. Never disconnect or disable the mains earth. If the earth wire is missing, or if in doubt as to whether the circuit is adequately earthed, consult a qualified electrician
- DANGER:** Using the machine with a damaged mains lead may cause electric shock. Do not use the machine if the mains lead is damaged. Never pull the machine by the mains lead.
- DANGER:** Passing the sander over its mains lead may lead to injury or fatal electric shock. Keep the lead away from the lower part of the machine to avoid contact with the abrasive.. Always keep the mains lead raised above the machine.
- DANGER:** The machine's moving parts can cause serious injury and/or damage. Keep hands, feet and loose clothing away from all moving parts.
- DANGER:** Carrying out maintenance or replacing the dust bag may cause injury to the operator and/or others in the vicinity if the machine is still connected to the mains supply.



- WARNING:** Failure to read and follow all the instructions on the machine and in this handbook may lead to serious injury and/or damage. Read and follow all safety instructions. Check that all plates, stickers, warnings, precautions and instructions are in place on the machine. For replacements, contact your authorised **K&T** dealer.
- CAUTION:** Maintenance and repairs carried out by unauthorised personnel may lead to injury or damage.
- CAUTION:** Failure to store the machine in a dry place will cause damage. Always store the machine in a dry place.

## **OPERATING INSTRUCTIONS**

The machine is designed for commercial use, for example in hotels, schools, hospitals, offices, factories and shops.

The information below highlights potentially dangerous conditions for the operator and/or for the machine. Read this handbook carefully and become familiar with the machine. Learn to foresee when these conditions may arise. Use all the available safety systems on the machine. Take all steps necessary to train personnel in the use of the machine. Report any machine damage or malfunction immediately.

1. Keep hands and clothing away from moving parts.
2. Always work with the suction group operating and correctly positioned.
3. Do not detach suction pipes with the vibrator motor running.
4. Always disconnect the mains lead before beginning maintenance.
5. Given its weight, exercise caution when moving the machine.
6. Always use the machine in well-ventilated areas.
7. Dispose of sawdust correctly (see page 7).





## MACHINE SPECIFICATIONS

|   |  |
|---|--|
| ABRASIVE SIZE   | 300 x 460 mm (18 x 8")   |
| MOTOR EUROPE<br>USA   | 230-240V~ 50 Hz 1.1 kW<br>115V~ 60 Hz 1.1 kW   |
| SUCTION EUROPE<br>USA   | 230-240V~ 50 Hz 0.8 kW<br>115V~ 60 Hz 0.8 kW   |
| CONTROL LEVER   | CAN BE OPERATED WITH HANDS ON GRIP   |
| MOTOR SAFETY  | DUAL START CONSENT. RELEASING SIDE BUTTONS<br>STOPS MOTOR  |
| WHEELS  | Ø 100 mm REPLACEABLE   |
| BEARING   | PERMANENT LUBE RADIAL  |
| NOISE (continuous weighted A sound<br>pressure at 0.4 m from grips and 1.5 m from<br>floor) | ≤ 90 dB(A)   |
| MACHINE DIMENSIONS  | 500 x 500 x 1170 mm  |
| MACHINE + SUCTION GROUP WEIGHT  | 46 kg + 9 kg   |
| PACKED DIMENSIONS   | 2 boxes<br>540x540x760; 380x130x1230   |
| GROSS WEIGHT  | 55 kg  |
| STANDARD EQUIPMENT  | GREEN PAD<br>DOUBLE FACE SANDPAPER 60- 100 GR. SPANNER /<br>ALLEN KEY 5 mm USE AND MAINTENANCE<br>HANDBOOK |

## STARTING AND STOPPING THE MACHINE

Proceed as follows to start the machine:

1. Become familiar with the machine and read all instructions on danger, warnings and precautions. Make certain all operators have read this handbook
2. Locate the electricity supply. The socket must be compatible with the plug. To prevent electrical hazard, the socket must be earthed and protected by a 20A fuse.
3. Keep the mains lead clear of the machine base
4. Fit the abrasive as described in "FITTING THE ABRASIVE", page 11
5. Make sure the abrasive is positioned correctly between floor and green pad
6. Connect the plug to the socket
7. Using both hands, lift the release levers (F fig. 2), turn the handle toward the outside then release the lever.
8. Turn the suction group switch on, position "I".
9. Holding the grip (E fig. 2) firmly, press the consent button on the upper end of the handle (H fig. 2) .
10. Holding the consent button down, start the machine by pressing the switch levers (G fig. 2) using either the right or left lever.

To stop the machine:

1. Release the switch levers (G fig. 2) and return the handle to vertical, lifting the release levers with both hands (F fig. 2)

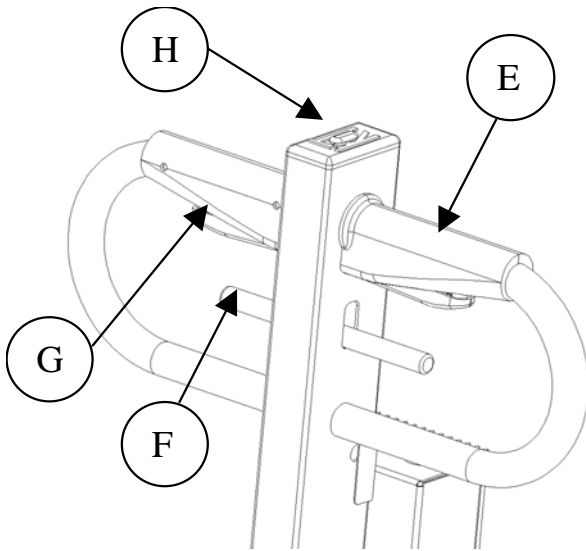

**Fig. 2**  
E – GRIP  
F – RELEASE LEVER  
G – SWITCH LEVER  
H – CONSENT BUTTON

## MACHINE ADJUSTMENT

### ADJUSTING GRIP HEIGHT

The lever on the handle can be used to adjust the inclination for the ideal working position.

### FITTING THE ABRASIVE

Lock the handle vertical and using it as a lever, raise the base. Place the GREEN PAD on the machine plate paying attention to align all four sides.

Place the DOUBLE FACE abrasive paper, of the appropriate grade, on the surface to sand and bring the machine over it to align the GREEN PAD with the paper itself.

Begin sanding.

**WARNING:**

**The abrasive is in the correct position when it does not protrude from the machine plate.**

**DANGER:**

**If the abrasive is not sufficiently tight or is damaged, it could tear when sanding and cause damage to both the machine and the floor.**



## **PERIODIC MAINTENANCE**

To keep the machine in good working condition, the following items should be periodically checked and maintained:

### **SANDING CHAMBER** (*USER MAINTENANCE*)

Periodically clean the chamber of sawdust.

### **SANDING PLATE** (*USER MAINTENANCE*)

Periodically check the sanding plate surface. Remove any dirt or grime.

### **WHEELS** (*USER MAINTENANCE*)

Periodically remove dirt from the machine body and wheels. Dirt on the wheels may cause undulations in the sanded surface.

### **DUST SUCTION GROUP** (*USER MAINTENANCE*)

Remove the suction group motor and tip the container to remove the sawdust.

### **BEARINGS** (*SERVICE CENTRE ONLY MAINTENANCE*)

**After the first 5000 hours** check cam bearings for wear and/or damage

## **REPLACEMENT PARTS**

Always use original **K&T** replacement parts. The guarantee does not cover non-original **K&T** parts or repairs/adjustments carried out by unauthorised personnel.





ORBITAL SANDER FOR WOODEN FLOORS  
Planfix Pro 55

**ED 03**  
PG.12/13

### TROUBLESHOOTING (FOR USER)

| <b>FAULT</b>                 | <b>CAUSE</b>  | <b>REMEDY</b>   |
|------------------------------|---|---|
| Sanding insufficient         | worn or unsuitable abrasive   | replace abrasive  |
| Scored surface               | defective abrasive  | replace abrasive  |
| Insufficient dust collection | collection bin over 1/3 full,<br>suction and/or delivery pipe obstructed  | empty bin<br>clean air pipes  |
| Motor not starting           | faulty microswitches<br>faulty condenser<br>faulty motor<br>insufficient voltage due to faulty supply<br>no voltage from supply | call an authorised K&T dealer<br>call an authorised K&T dealer<br>call an authorised K&T dealer<br>check mains and connections<br>check mains and connections |