



**Operating instructions
Floor sander PYTHON C 3,2kW/50Hz
with gentle lifting lever
Item no 048666**



CE Art. Nr. 049275



**Operating instructions
Parquet floor sander Python C 3,2kW/50Hz
with gentle lifting lever**

©  2007

Reproduction on whole or in part requires written permission from
Hermann Frank GmbH & Co. KG, 75038 Oberderdingen, Germany.
All rights reserved.

No liability for any damage arising from the use of this brochure.
Subject to alterations.

Hermann Frank GmbH & Co. KG
Östliche Bahnhofstraße 8
75038 Oberderdingen
Germany
Tel.: +49 (0)72 58 / 60 88-0
Fax: +49 (0)72 58 / 60 88-11
info@hermannfrank.de
www.hermannfrank.de

Stand: Februar 2008



This brochure uses the symbol



to mark important instructions for safety and preventing damage.

Please give special attention to the marked instructions.

They refer to a potentially dangerous situation. Failure to comply can result in fatal or severe injuries and damage to property.



**Operating instructions
Parquet floor sander Python C 3,2kW/50Hz
with gentle lifting lever**

Contents

1	Introduction.....	6
2	Scope of delivery.....	7
3	Machine specifications PYTHON C	8
3.1	Important components.....	8
3.2	Technical data	9
3.3	Safety and machine protection facilities	9
4	Proper use.....	9
5	Installing the guide tube	10
6	Disassembling for transport	11
6.1	Removing the guide tube	11
6.2	Removing the motor	12
7	Operating the PYTHON C	14
7.1	Protective clothing and equipment	14
7.2	Fitting the dust bag	15
7.3	Safety instructions regarding dust	16
7.4	Disposing of sanding dust	17
7.5	Replacing the sanding belt	18
7.6	Adjusting the sanding pressure	19
7.7	Safety instructions for electric cable and connectors	20
7.8	Connecting the PYTHON C to the mains power	20
7.9	Remarks about sanding parquet and plank floors	22
7.10	Sanding with the PYTHON C	25
8	Maintenance	30
8.1	Changing the sanding drum	30
8.2	Adjusting the running wheels	32
8.3	Adjusting the castor wheels	34
8.4	Adjusting the tension roller	35
8.5	Tightening the V-belts.....	36
8.6	Guarantee.....	37



9	Parts lists	37
---	-------------------	----



**Operating instructions
Parquet floor sander Python C 3,2kW/50Hz
with gentle lifting lever**

1 Introduction

Dear customer,

you have decided in favour of the FRANK parquet floor sander PYTHON C, the correct choice with respect to quality and performance.

The PYTHON C is the result of a consistent implementation of many years of experience.

This machine combines an extraordinary high sanding performance and an excellent sanding quality, together with an easy to operate, proven and reliable technology.

This operating instructions contain important informations for the use and safe operation of the PYTHON C.



Caution!

Read these operating instructions carefully before assembling or operating the PYTHON C. Ensure that all operators read these operating instructions prior to operate the machine.

Adherence to the safety notes helps to protect against potential dangers for health and personal safety and to prevent an improper utilisation of the machine.

Before starting to work, make yourself familiar with the operation of the machine. It's too late if you do it while working!

Never allow anybody without sufficient skills and knowledge to operate the machine.

2 Scope of delivery

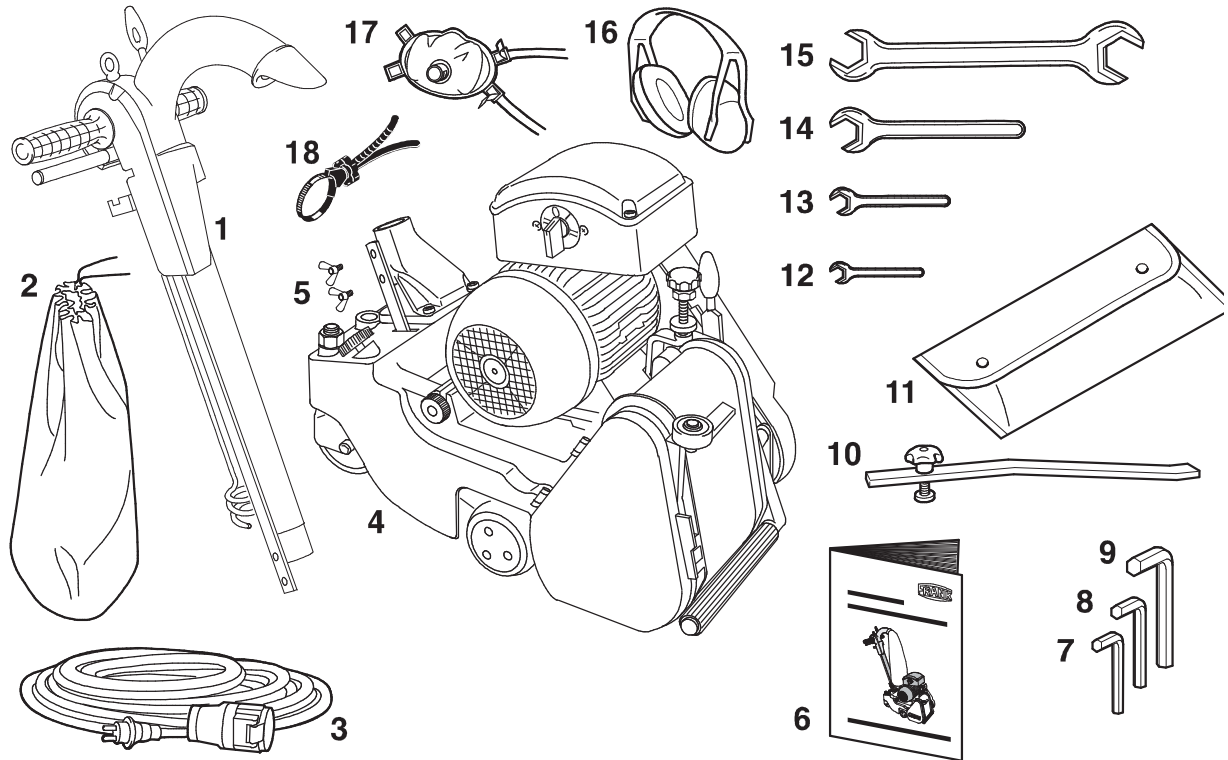

- 1 guide tube
- 2 dust bag
- 3 cable with plug and coupling
- 4 lower part of the machine with motor
- 5 wing screws (2 pieces)
- 6 operating instructions
- 7 hexagon socket screw key 5 mm
- 8 hexagon socket screw key 6 mm
- 9 hexagon socket screw key 10 mm
- 10 running wheel adjusting tool
- 11 tool pouch
- 12 fork wrench 10 mm
- 13 fork wrench 13 mm
- 14 fork wrench 24 mm
- 15 double fork wrench 30/36 mm
- 16 hearing protectors
- 17 respirator
- 18 Multiclip

3 Machine specifications PYTHON C

3.1 Important components

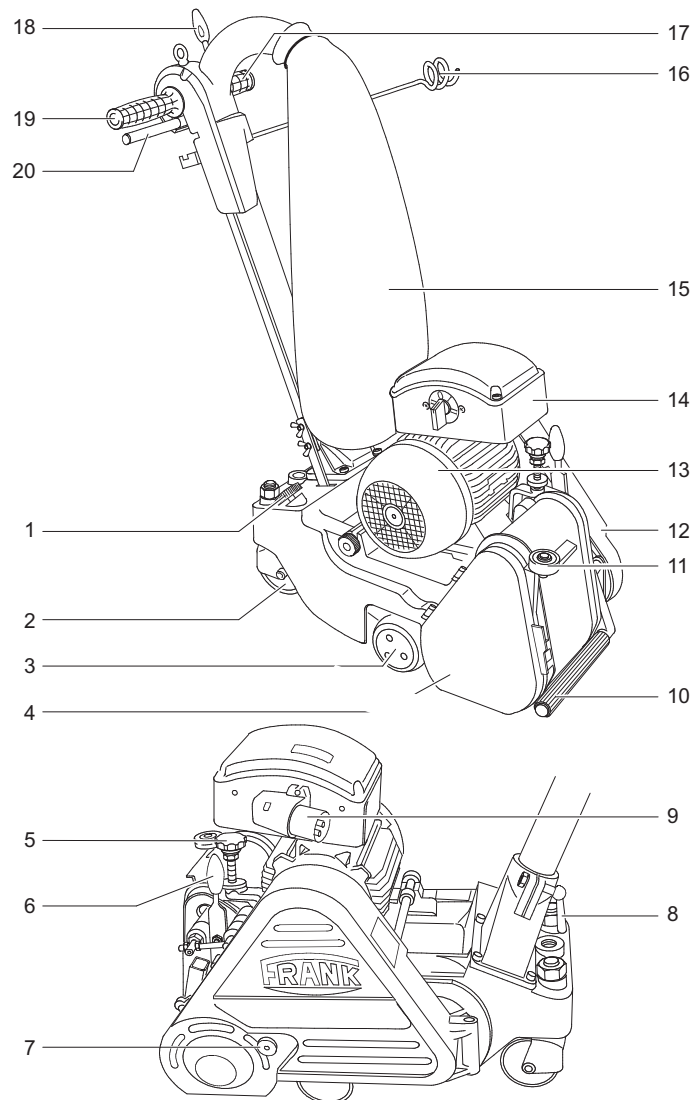

- | | |
|-----------------------------|-------------------------|
| 1 pressure regulating screw | 11 bumper wheel |
| 2 castor wheels | 12 belt guard |
| 3 running wheels | 13 motor |
| 4 drum cover | 14 switch box |
| 5 V-belt tension screw | 15 dust bag |
| 6 tension lever | 16 cable arm |
| 7 knurled nut | 17 left hand grip |
| 8 clamping lever | 18 main lifting lever |
| 9 motor plug | 19 right hand grip |
| 10 carrying handle | 20 gentle lifting lever |



3.2 Technical data

Single-phase AC motor 240 V, 60 Hz
Motor power 3,2kW
Sanding drum speed 2100 rpm
Sanding width 250 mm
Sanding belt dimensions 250 mm x 750 mm, endless
Machine weight 90 kg

3.3 Safety and machine protection facilities

PYTHON C is equipped with an

- **overcurrent cutout** and an
- **no-volt release**

The overcurrent cutout protects the machine from damage and persons from endangering in the case of short circuits.

The no-volt release prevents uncontrolled restart of the machine after power failure. The motor will **not** restart automatically when the power returns, it will have to be switched on again.

4 Proper use

The parquet floor sander PYTHON C is suitable for dry sanding of parquet and plank floors. No other use is allowed.



Caution!

Never use PYTHON for wet procedures (mortal risk from electric shock)!

5 Installing the guide tube

Note: The Python C is delivered with the guide tube (1) removed.



Caution!

Injury to the operator or other persons could occur or damage could occur if the machine starts up unintentionally. Disconnect the machine from the power supply before working on the machine!

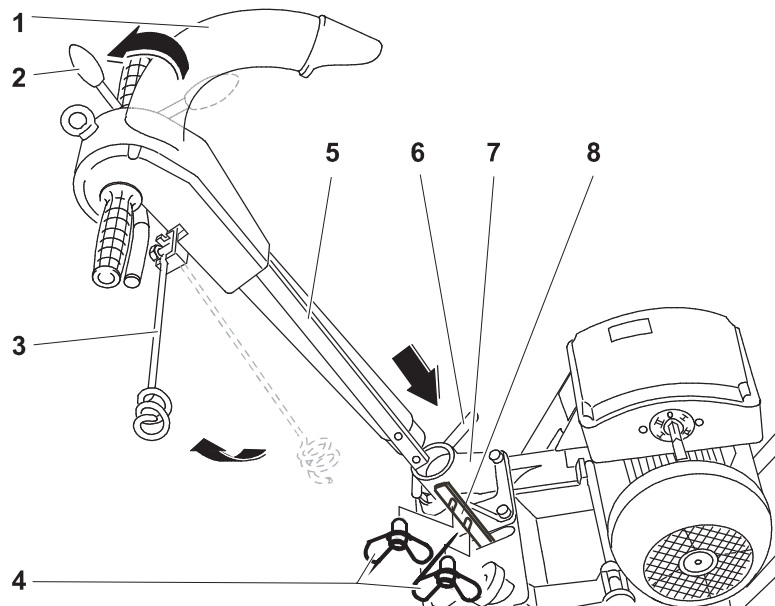

Instructions:

1. Insert the guide tube (1) into the guide tube support (7). The curved section of the tube must face toward the motor. Clamp the guide tube by means of the clamping lever (6) located on the guide tube support.
2. Fit the connector (8) into the both screws of the pull rod
3. Move the main lifting lever (2) into the rear position to raise the sanding drum from the floor.
4. Tighten both wing nuts

6 Disassembling for transport

For easy transportation the motor and the guide tube can be removed.

6.1 Removing the guide tube



Caution!

Injury to the operator or other persons could occur or damage could occur if the machine starts up unintentionally. Disconnect the machine from the power supply before working on the machine!

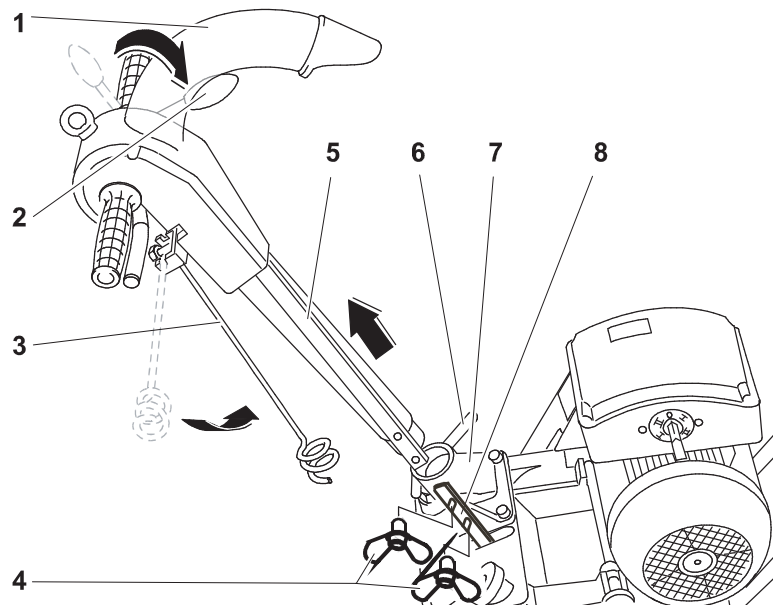

Instructions:

1. Fold down the cable arm (3).
2. Move the main lifting lever (2) to the front position in order to lower the sanding drum to the floor. This removes the load from the control rod (5).
3. Loosen both of the wing screws a little (4). Push the handle down to detach the control rod (5) from the connector (8).
4. Open the guide tube support (7) with the clamping lever (6) and pull the guide tube (1) out.

6.2 Removing the motor



Caution!

Injury to the operator or other persons could occur or damage could occur if the machine starts up unintentionally. Disconnect the machine from the power supply before working on the machine!

Instructions:

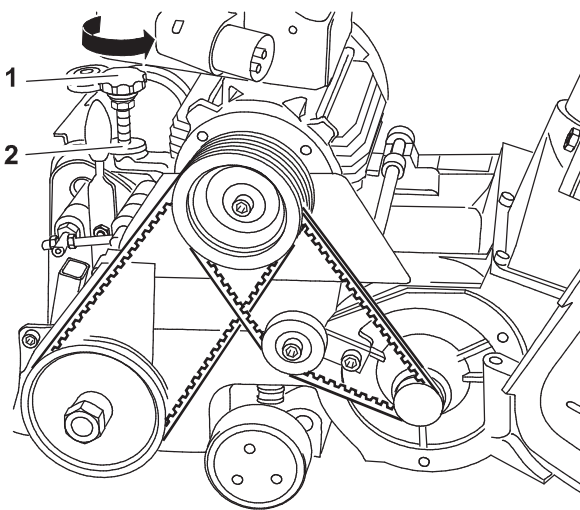

1. Make sure that the motor switch is in the off position and that the mains cable is disconnected from the motor plug.
2. Unscrew the knurled nut from the belt guard and open the belt guard.
3. Loosen the lock nut (2) on the belt tension screw.
4. Turn the belt tension screw (1) counterclockwise. This will lower the motor and release the tension on the belts.
5. Remove the belts.

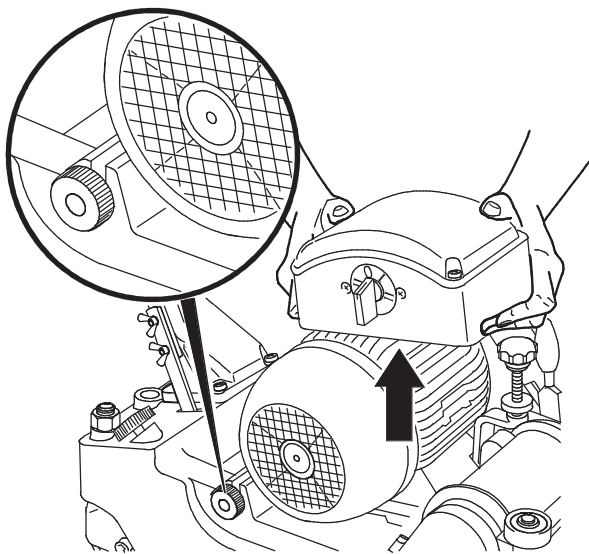

6. Remove the knurled nut from the motor bracket.
7. Now you can remove the motor.



**Operating instructions
Parquet floor sander Python C 3,2kW/50Hz
with gentle lifting lever**

7 Operating the PYTHON C

7.1 Protective clothing and equipment



Caution! Wear hearing protectors!

The supplied hearing protectors must be worn when using the machine.

The following sound level values have been measured for the parquet floor sander PYTHON C according to DIN 45 645:

Idle mode LEQ = 85 dB(A)

Working mode LEQ = 87 dB(A)

The noise produced when the machine is working depends on various factors. Local conditions such as room size and quality of the floor affect noise development.



Caution! Wear a respirator!

When using the parquet floor sander PYTHON C and when disposing of the sanding dust, always wear a respirator (see chapter 7.3 and 7.4). Wear the respirator which is supplied with the accessories.



Caution! Wear safety goggles!

When using the parquet floor sander PYTHON C and when working on PYTHON C, always wear safety goggles to protect your eyes.



Caution! Wear proper working clothing!

When using the parquet floor sander PYTHON C and when working on PYTHON C, never wear loose clothing. This can get caught up in moving parts.

7.2 Fitting the dust bag



Caution!

Only use original FRANK dust bags for the parquet floor sander COBRA.



Caution!

The dust bag must be firmly fitted to the dust pipe before sanding.

Instructions:

1. Pull the dust bag over the dust pipe to behind the pipe reinforcement.
2. Fasten the dust bag here using the Multiclip.

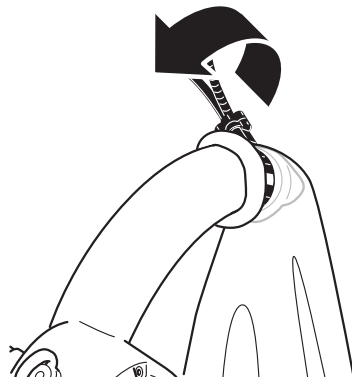

7.3 Safety instructions regarding dust



Caution! Ultra-fine sanding dust!

Always wear a respirator when sanding parquet and plank floors (is included with the accessories).

When the machine is used for its proper purpose, the sanding of wooden floors naturally produces dust. The machine has an integrated dust collecting system which blows the dust into the dust bag. The dust is collected in the dust bag. Even so, this cannot prevent fine and ultra-fine dust being produced when using the machine.



Caution! Health risk!

Wood dust, particularly when treated with impregnating agents, solvents and coatings, can cause allergic reactions (e.g. of the skin or respiratory system) after a sensitization period. Beech and oak dust is classified as being carcinogenic (cancer of the nasal mucous membranes). Dust from other kinds of wood is suspected of having a carcinogenic effect.



Caution! Fire risk!

No smoking while sanding!

**All ignition sources are prohibited in rooms where sanding work is being carried out!
Air the rooms thoroughly.**

Together with an ignition source and the oxygen in the air, wood dust can cause fires and explosions.



Caution! Fire risk!

Sanding over metal parts such as nails can produce sparks which are blown into the dust bag together with the wood dust. Here the glowing metal chips can still cause a fire even hours later.

Every time after the machine has stopped and at the end of working, the sanding dust contained in the dust bag must always be disposed of immediately in a fire-proof, non-flammable container. The container must be covered with a fire-proof, non-flammable lid. Store the container only outdoors.

7.4 Disposing of sanding dust



Caution! Fire risk!

Because of the fire risk, the sanding dust contained in the dust bag must always be disposed of immediately every time after the machine has stopped and at the end of working. The sanding dust must be disposed of immediately in a fire-proof, non-flammable container. The container must be covered with a fire-proof, non-flammable lid. Store the container only outdoors.



Caution!

At the latest when 1/3 full, the sanding dust contained in the dust bag must be disposed of, because the dust collecting capacity is reduced when the bag is any fuller. The sanding dust must be disposed of in a fire-proof, non-flammable container. The container must be covered with a fire-proof, non-flammable lid. Store the container only outdoors.



Caution!

Always wear a respirator when disposing of the sanding dust (included with the accessories).

7.5 Replacing the sanding belt



Caution! Danger from machine starting up!

When replacing the sanding belt, there is a risk from the machine starting up unintentionally. Always disconnect the parquet floor sander from the mains power before working at the sanding belt.



Caution! Risk of cutting your hands!

The sanding grains of the sanding belt have sharp edges. Always wear safety gloves when replacing the sanding belt.

Instructions for replacing the sanding belt:

1. Switch the machine off.
2. Disconnect the machine from the mains power.
3. Open the sanding drum cover (1).
4. Move the tension lever (2) forward. The sanding belt which was held under tension is now released. Pull it out to the side.
5. Insert a new sanding belt.
6. Clamp the new sanding belt by moving the tension lever (2) backward.
7. Close the sanding drum cover (1).

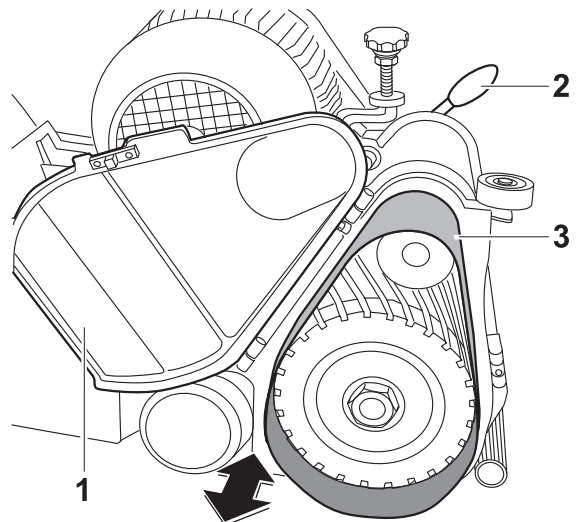

7.6 Adjusting the sanding pressure

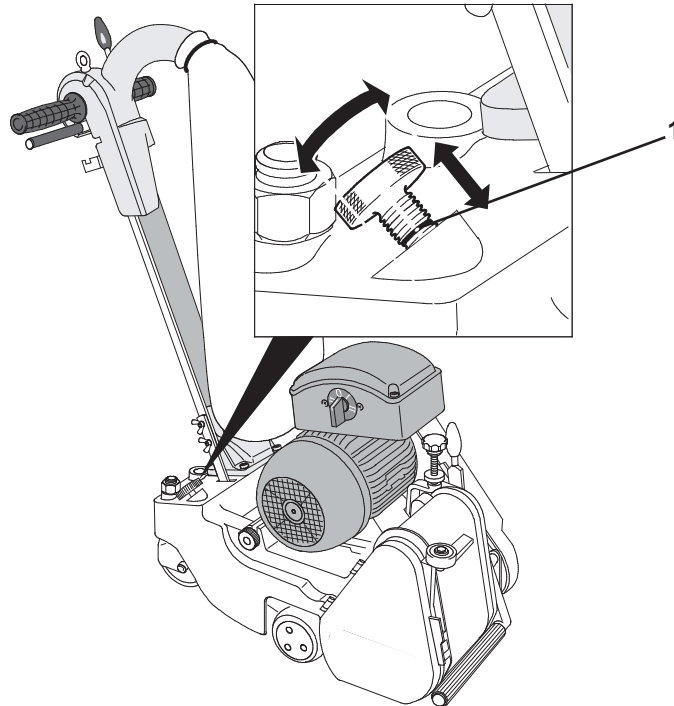

Use the pressure regulating screw to adjust the required sanding pressure.

High sanding pressure:

Turn the pressure regulating screw inwards as far as it will go.

Low sanding pressure:

Turn the pressure regulating screw outwards to the lower marking (2) on the screw thread.

7.7 Safety instructions for electric cable and connectors



Caution! Mortal risk from electric shock!

There is a mortal risk from electric shock if the machine is used when the electric cable or connectors are damaged. If the electric cable and connectors are damaged, they must be replaced by a qualified electrician.



Caution! Mortal risk from electric shock!

Running over the electric cable with the sander entails a mortal risk from electric shock!
 Never point the machine towards the cable!

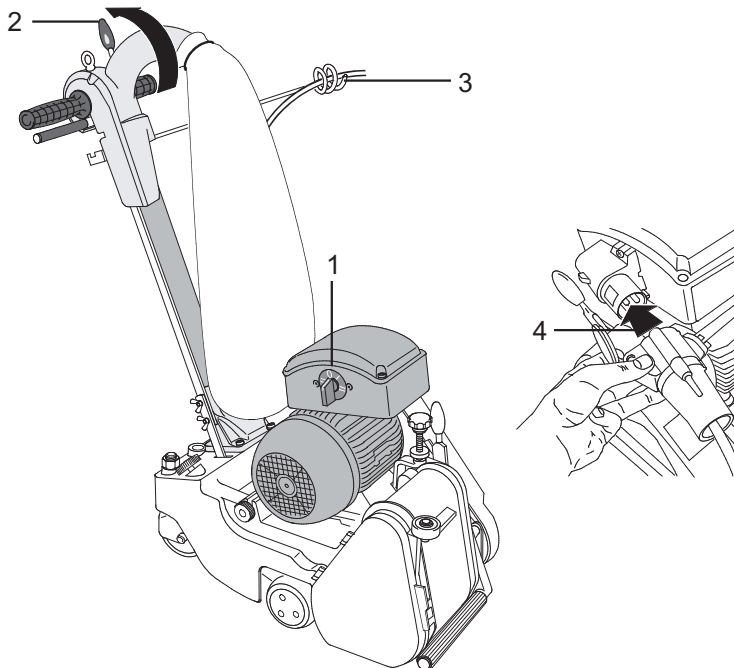

7.8 Connecting the PYTHON C to the mains power

Instructions for connecting to mains power:

1. Make sure that the switch (1) is in the off position. The machine must be switched off before connecting up to the mains power.
2. The main lifting lever for the sanding drum (2) must be moved backward so that the sanding drum is raised from the floor.
3. Hang the swivelling cable arm (3) into the left or right cable arm bracket as required. Wind the mains cable through the curl at the end of the cable arm (3) to keep the cable away from the sanding zone.
4. Connect the coupling (4) of the mains cable to the motor plug, which must be disconnected from mains power.
5. Connect the plug of the mains cable via a portable RCD (Residual Current Protective Device) to an adequately fused and earthed 230 V mains socket.



Caution!

Never switch the motor on if the sanding belt is not tightened.



Caution!

Never switch the motor on if the sanding drum is not raised from the floor.



Caution!

Risk of injuries from the machine starting up unintentionally! Disconnect the machine from the power supply when not in use, when changing the sanding belt and when carrying out any other work to the machine.

7.9 **Remarks about sanding parquet and plank floors**



Caution!

Check the floor to see if any boards are loose. These must be fastened before sanding.



Caution! Fire risk!

If there are nails in the floor, they must be countersunk so low every time before sanding that there is no risk of hitting a nail while sanding. Hitting a nail while sanding can produce sparks and can cause a fire. For example a spark can create a fire in the dust bag.

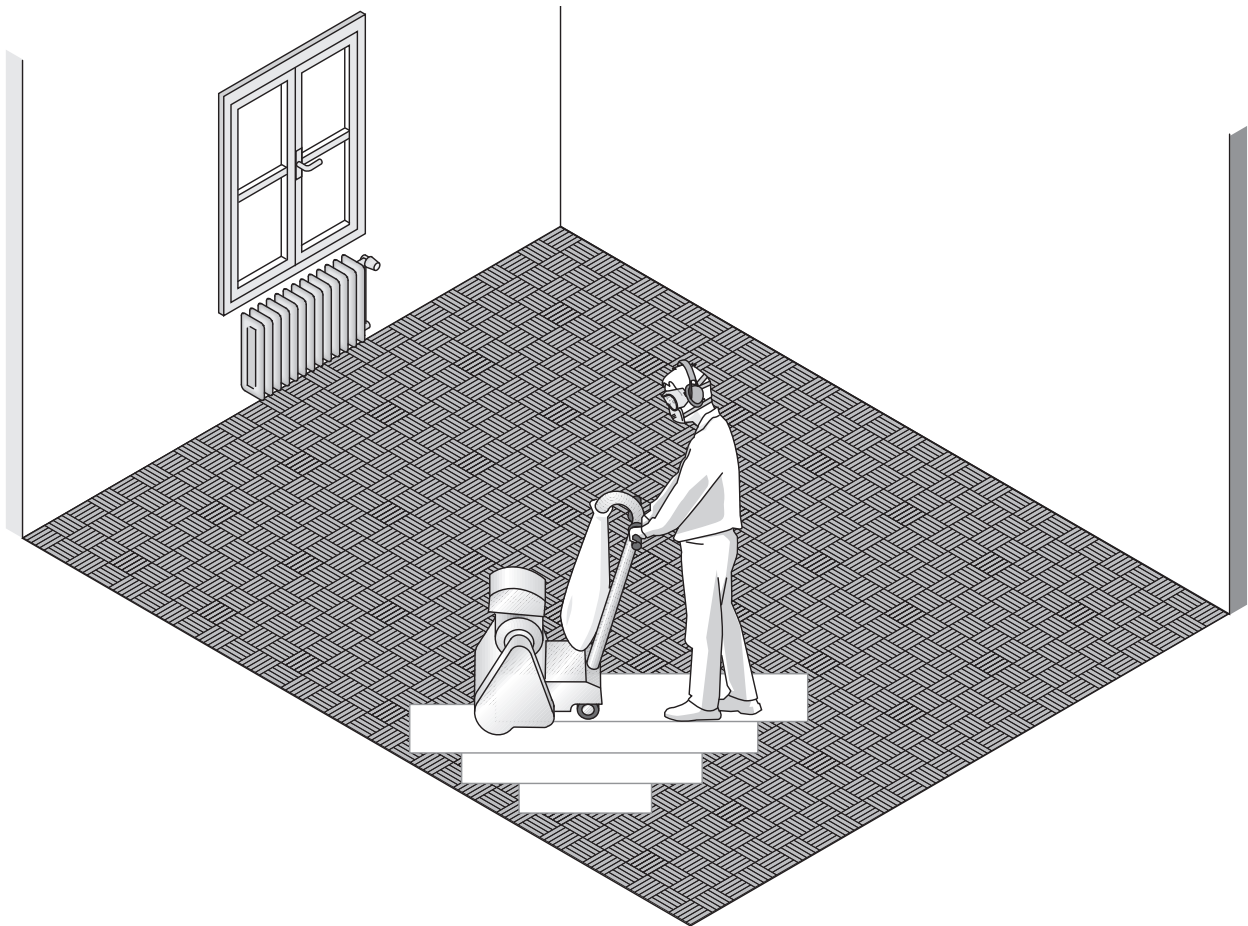

Floors are sanded in sanding paths which are arranged overlappingly from left to right.

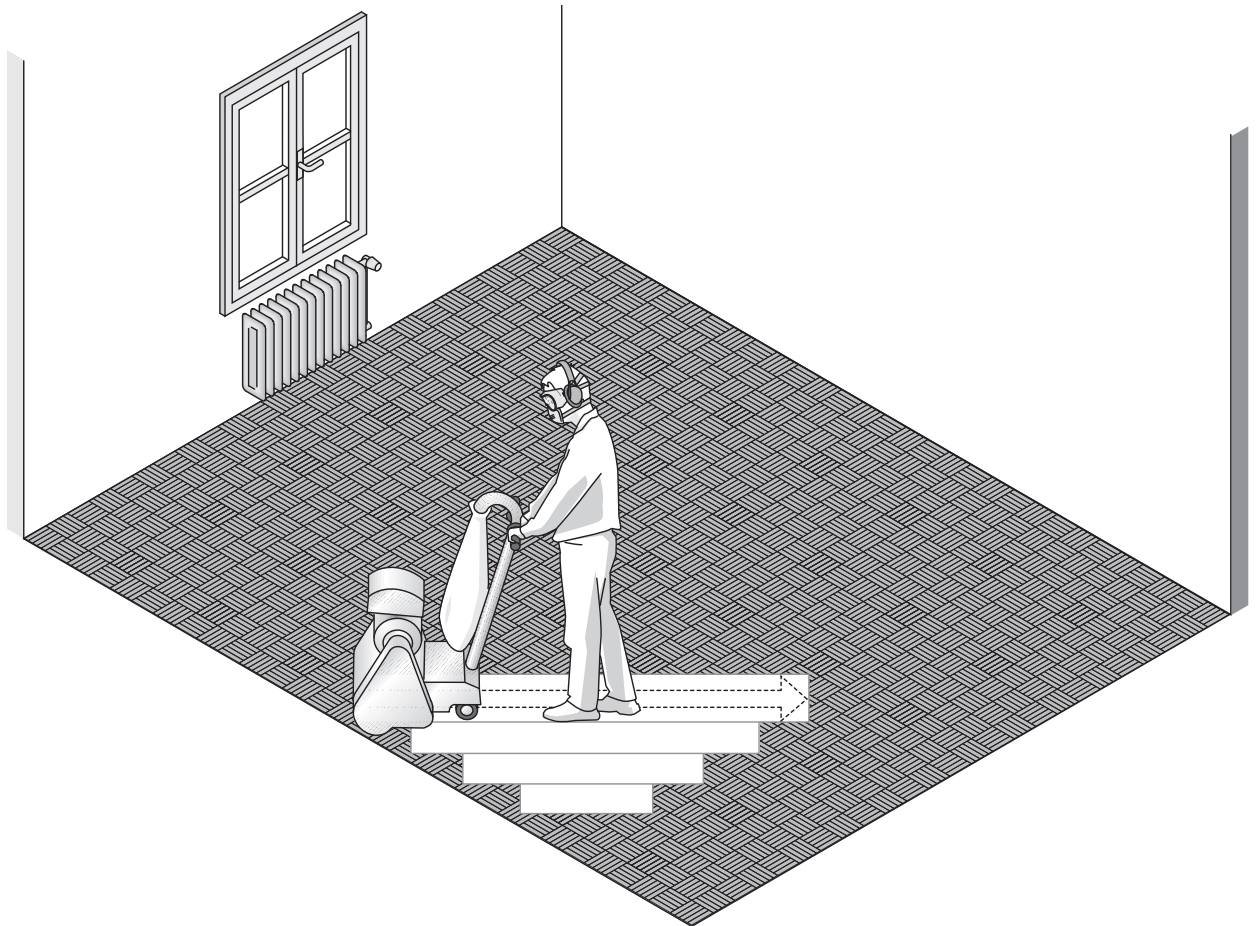

Each sanding path corresponds to one forward and one backward movement. The backward movement covers the same path as the precede forward movement.

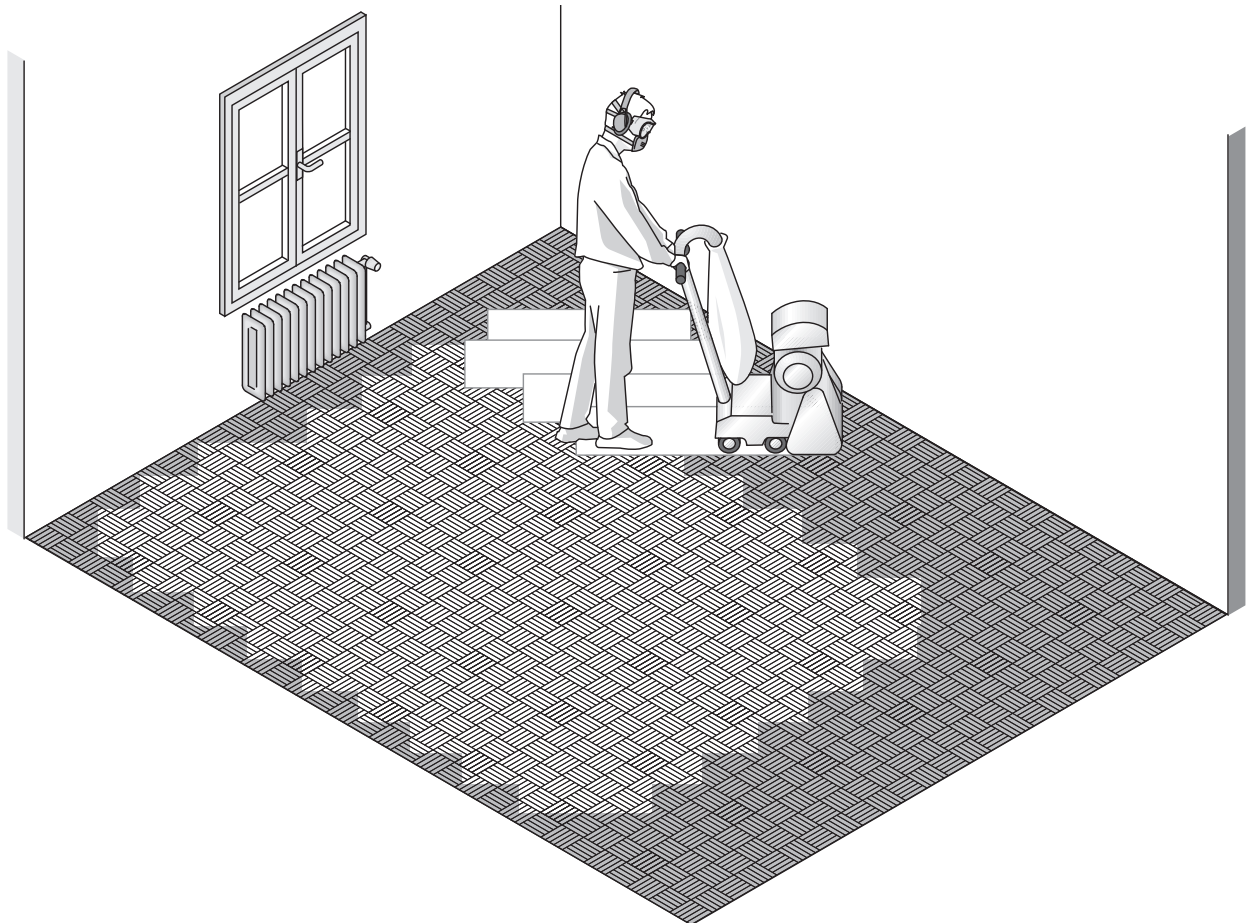

Because of the space needed for the person operating the machine and the machine itself, the floor is not sanded over an area of approximately 1.5 m to the wall behind the sander. Turn the machine 180° and sand the remaining area of the floor also in sanding paths which are arranged overlappingly from left to right. Make sure that the two areas are blended together without leaving any marks.

Note!

In most cases, the floor is sanded in several procedures. The whole floor area is sanded down in every sanding procedure.

Informations about the proper abrasive grits, sanding pressures and sanding directions for the several sanding procedures you will find in the brochure:

Sanding parquet and plank floors
 with the FRANK parquet floor sander **COBRA**
 and the FRANK edge sander **GECKO S**

7.10 Sanding with COBRA

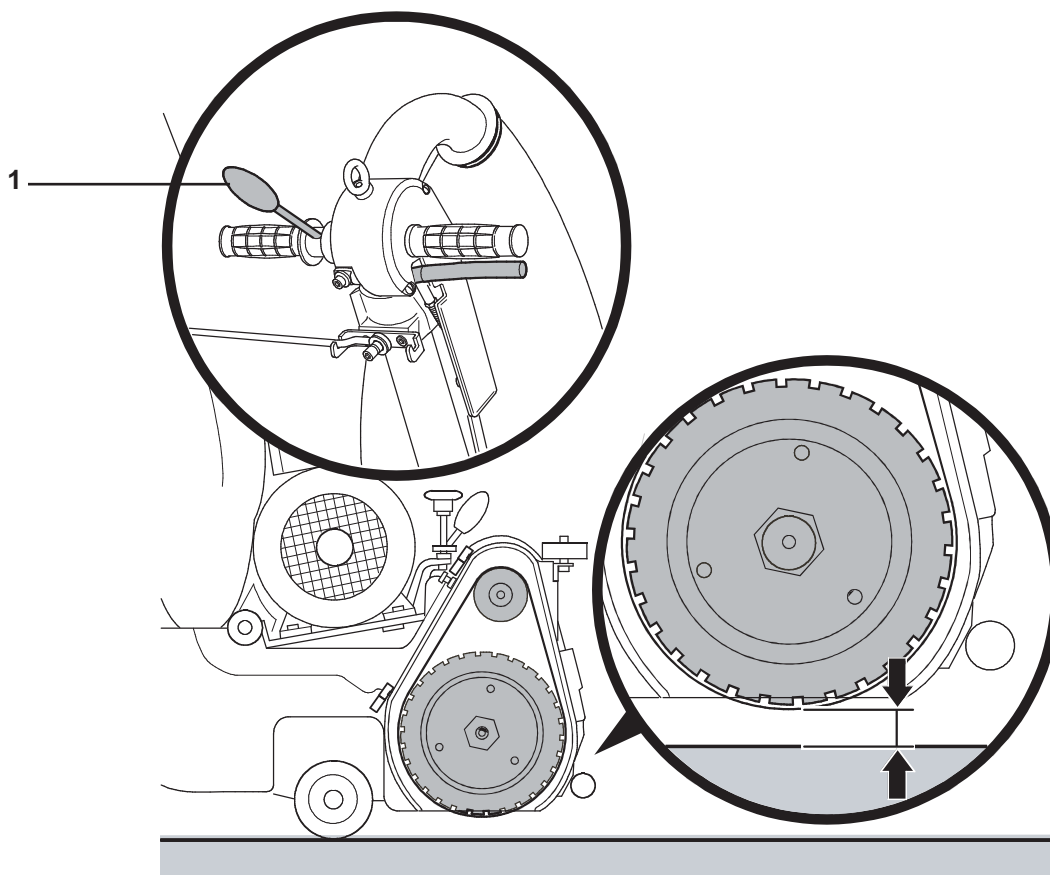

1. Before starting the machine, the main lifting lever for the sanding drum (1) must be in the rear position. The sanding drum is clearly raised from the floor. The distance to the floor is approx. 15 mm.
2. Before starting the machine, ensure that the sanding belt is tightened.
3. Bring the machine into the start position.
4. Set the switch to setting "I". Once the motor has started up, switch to setting "II". This gradual start-up procedure avoids high start-up currents.

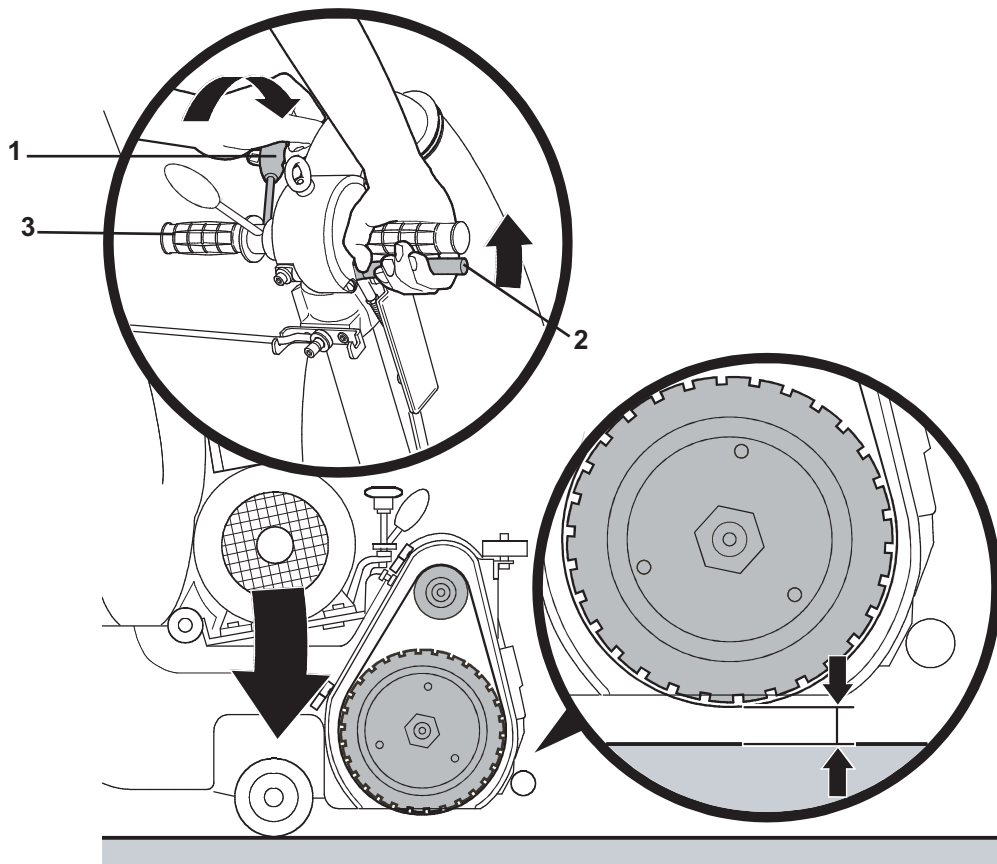

5. Before you lower the sanding drum to approx. 5 mm above the floor, you must pull the gentle lifting lever (2) up by bending the fingers of your right hand and hold in this position.
6. With your left hand, turn the left handle (3) to unlock the stop of the main lifting lever (1). While doing so, hold the gentle lifting lever (2) up with your right hand,
7. While you hold the gentle lifting lever (2) up, push the main lifting lever (1) forward. This lowers the sanding drum to approx. 5 mm over the floor. The gentle lifting lever (2) must always be held up because otherwise the sanding drum will be lowered to the floor.

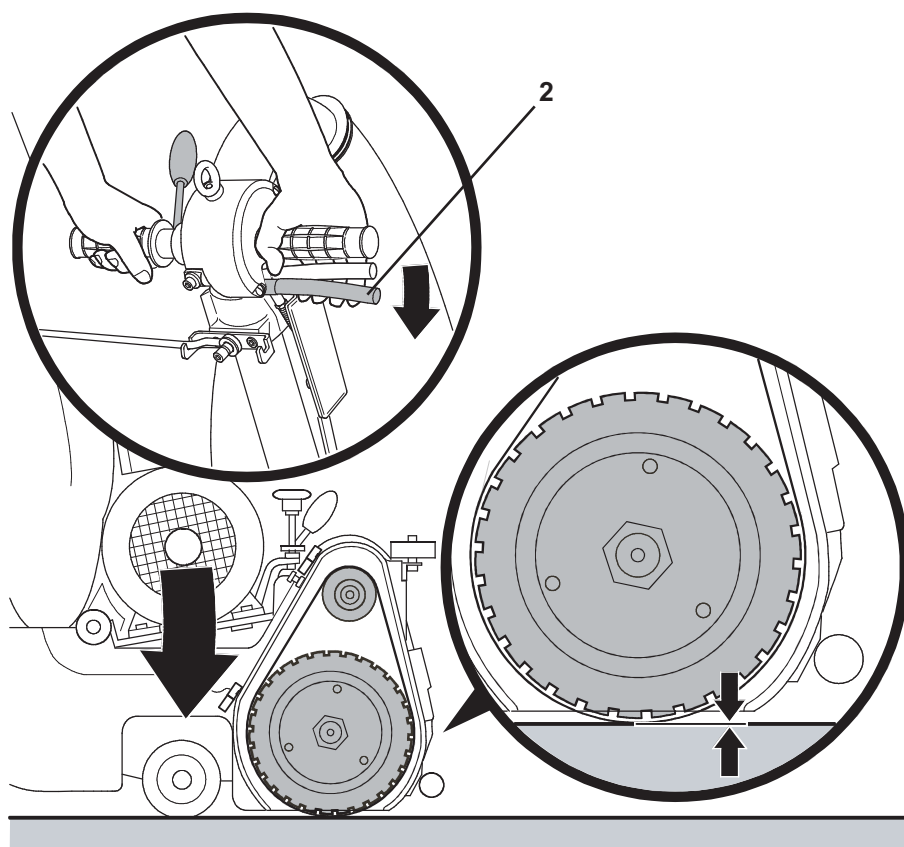

8. Now start on sanding the first path by slowly lowering the gentle lifting lever (2) while you are moving the machine forward evenly, thus lowering the sanding drum to the floor.



Caution!

Move the machine at an even pace while sanding to avoid creating any dents in the floor.

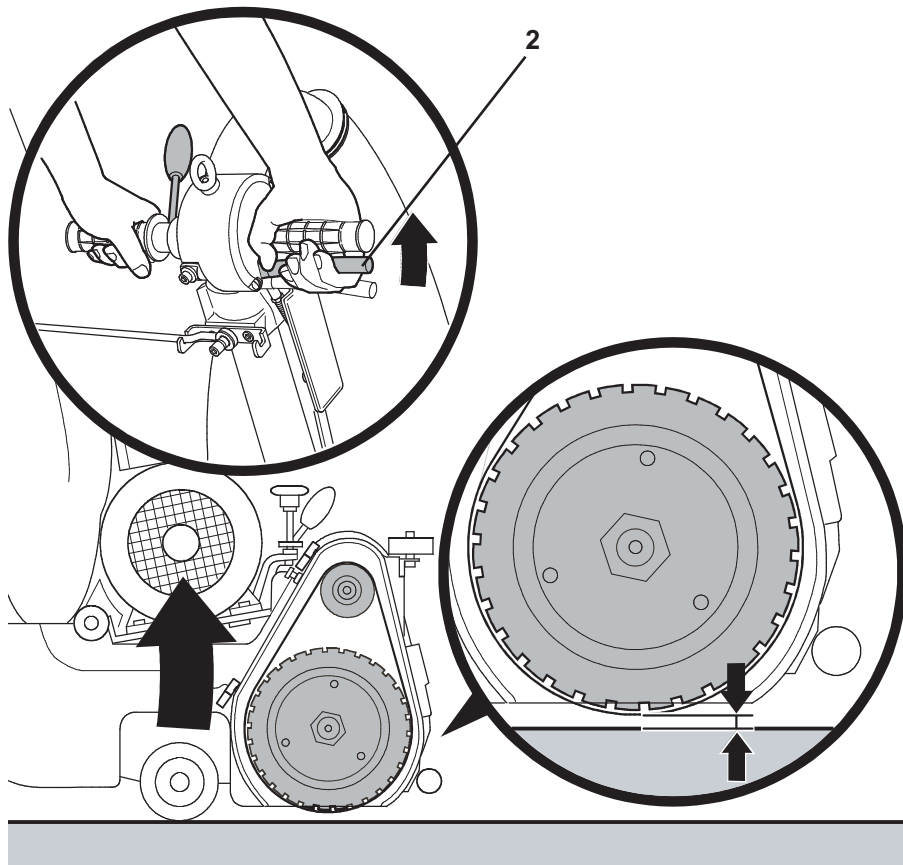

9. At the end of the forward movement, before the movement has finished, raise the sanding drum from the floor again by pulling the gentle lifting lever (2).

10. Every forward movement is followed by a backward movement. The backward movement covers the same path as the forward movement. For each forward movement, move the machine about 10 cm to the right of the sanding path you have just finished.



Caution!

Never allow the machine to come to a standstill for even a short moment while sanding because this would cause an indentation in the floor. This means that whenever changing between a forward and a backward movement, the sanding drum must be raised from the floor while the machine is still moving evenly, and only lowered when the machine is moving evenly again.

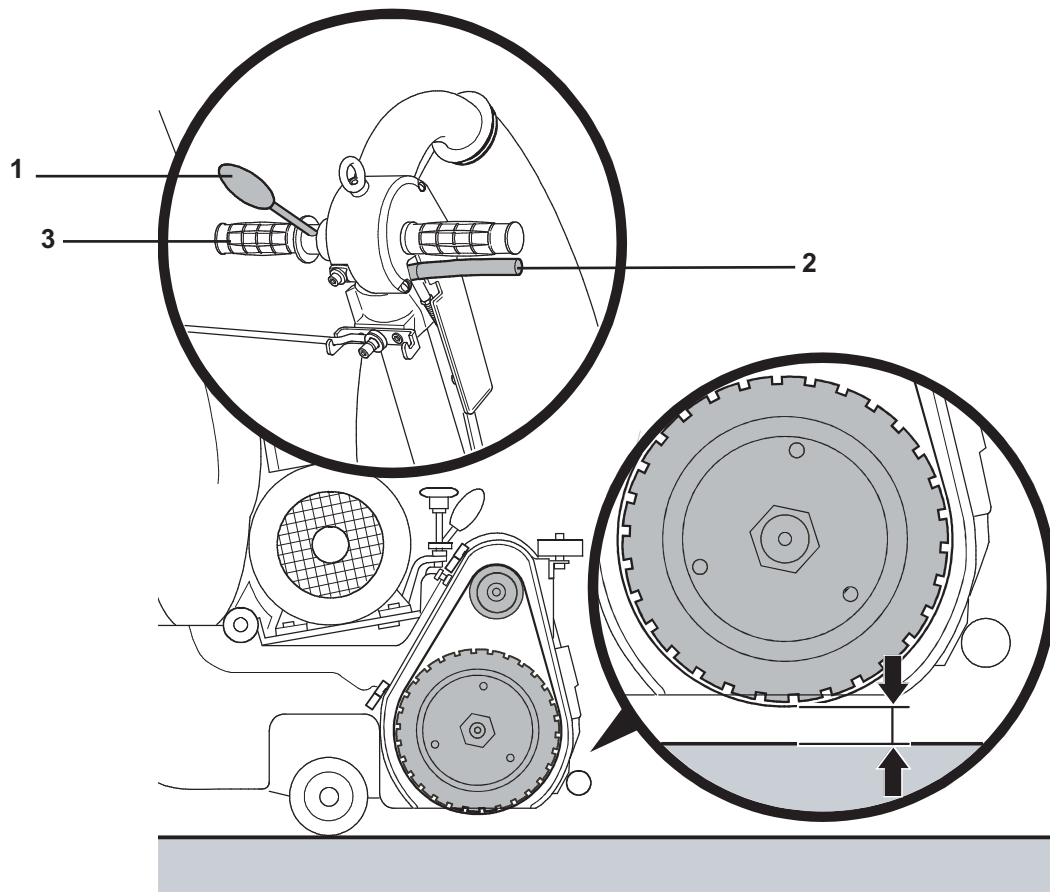

11. Stopping or interrupting the sanding procedure:

To stop or interrupt the sanding procedure, you must hold the gentle lifting lever (2) up with your right hand for as long as it takes for your left hand to move the main lifting lever (1) into the rear position. Do not release the gentle lifting lever (2) until this has been completed.

Then switch the motor off and disconnect from the mains power.

Safeguard the machine to prevent it rolling away.

The sanding dust contained in the dust bag must be disposed of immediately in a fire-proof, non-flammable container. The container must be covered with a fire-proof, non-flammable lid. Store the container only outdoors.

8 Maintenance

8.1 Changing the sanding drum

If the sanding drum is damaged or worn, it must be replaced.

Instructions:

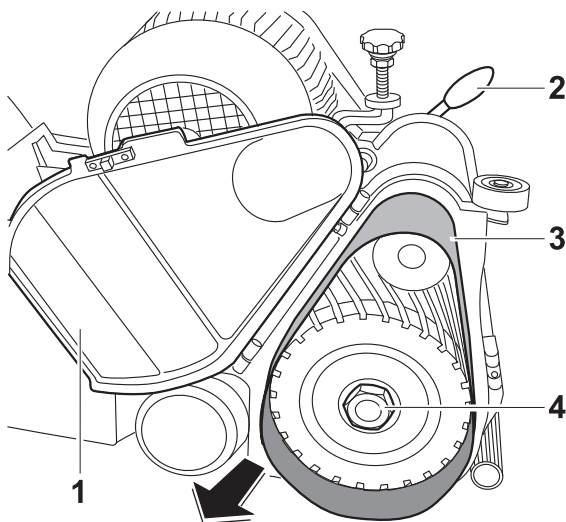

1. Turn the machine off.
2. Disconnect the machine from the mains power.
3. Open the sanding drum cover (1).
4. Fold the tension lever (2) forward to relieve the tension on the sanding belt.
5. Remove the sanding belt (3) to the side.
6. Unscrew the retaining nut (4):
 The retaining nut is glued to the threads of the sanding drum shaft to ensure that it will not fall off while the COBRA is in operation. To unscrew the retaining nut, use the double fork wrench that comes with the machine. Lower the sanding drum so it has contact with the floor to prevent it from turning while you are unscrewing the retaining nut.

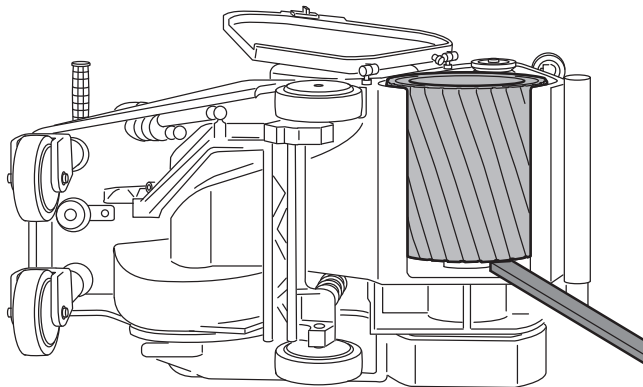

7. Lay the machine on its left side.
8. Press against the sanding drum carefully with a flat iron bar.
9. Remove the sanding drum out of the machine.
10. Be careful no to loose the parallel key.
11. Slide a new sanding drum on to the sanding drum shaft. The parallel key must fit properly in the slot on the sanding drum shaft.
12. Apply metal adhesive to the retaining nut and screw it back on the sanding drum shaft. Stand the machine up and lower the sanding drum to the floor to ensure that the sanding drum does not turn while you tighten the retaining nut in the next step. Tighten the retaining nut securely with the enclosed double fork wrench.
13. Pull the main lifting lever back to lift the sanding drum off the floor.
14. Close the sanding drum cover.
15. Ensure that the machine cannot roll away.

Note!

After changing the sanding drum, the surface setting on the machine must be newly adjusted.
(See chapter 8.2)

8.2 Adjusting the running wheels

If the machine only sands on one side, the surface setting must be adjusted. Following replacement of the sanding drum or running wheels, the surface setting must always be newly adjusted. To make a level, uniform setting, the sanding drum and the running wheels must rest on the same plane. The right running wheel is adjustable. The left wheel does not adjust.

Instructions:

1. Turn the machine off.
2. Disconnect the machine from the mains power.
3. Lay the machine on its left side.

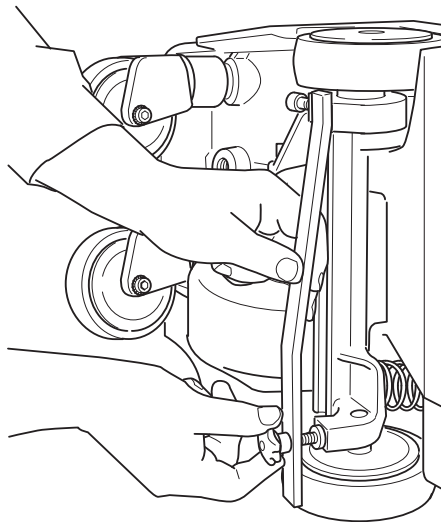

4. With the running wheel adjustment device determine the position of the left running wheel.

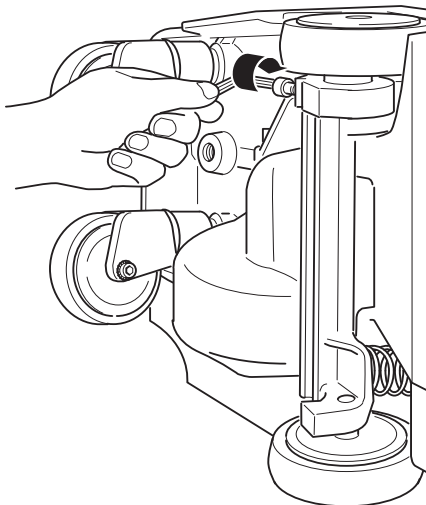

5. Loosen the cam fixation screw on the running wheel bracket next to the right running wheel.

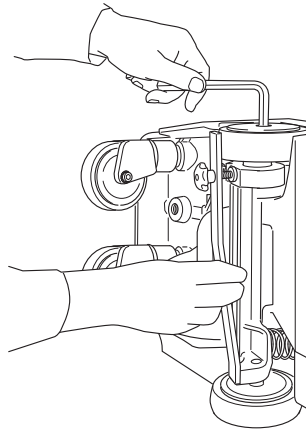

6. Adjust the right running wheel to the position of the left running wheel using the running wheel adjustment device. To accomplish this, turn the axle of the right running wheel with the hexagon socket screw key until the right running wheel slightly touches the tongue of the running wheel adjustment device.

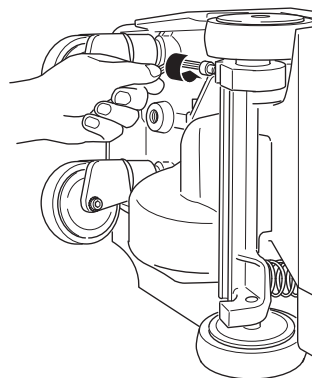

7. Tighten the cam fixation screw on the running wheel bracket next to the right running wheel securely.

8.3 **Adjusting the castor wheels**

Instructions for adjusting the castor wheels:

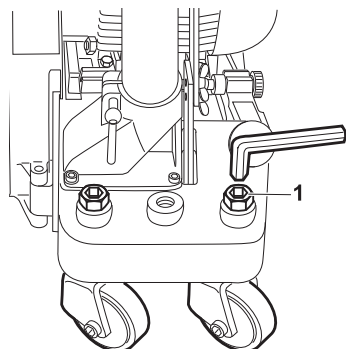

1. Turn the machine off.
2. Disconnect the machine from the mains power.
3. Loosen the lock nut (1).
4. Turn the castoring shaft with the hexagon socket screw key until both of the castor wheels bear weight.
5. Tighten the lock nut.

8.4 Adjusting the tension roller

The tension roller keeps automatically the track of the sanding belt concentrically to the sanding drum. If with time the sanding belt fails to run concentrically to the sanding drum, the tension roller must be newly adjusted.

Caution! Danger of injury!

Adjustments of the sanding belt while the machine is running and the sanding drum cover is open may only be performed by qualified personnel (in accordance with VBG 1, § 41 adjustment).



Caution!

Wear safety goggles and avoid loose clothing before making these adjustments.

Instructions:



Caution!

Before beginning with the following procedure, the main lifting lever must be pulled backwards to remove the sanding drum from the floor.

1. Make sure that the motor is in the off position and the machine is disconnected from the mains power.
2. Open the sanding drum cover.
3. Insert a sanding belt.
4. Shift the tension lever backwards to place tension on the sanding belt.

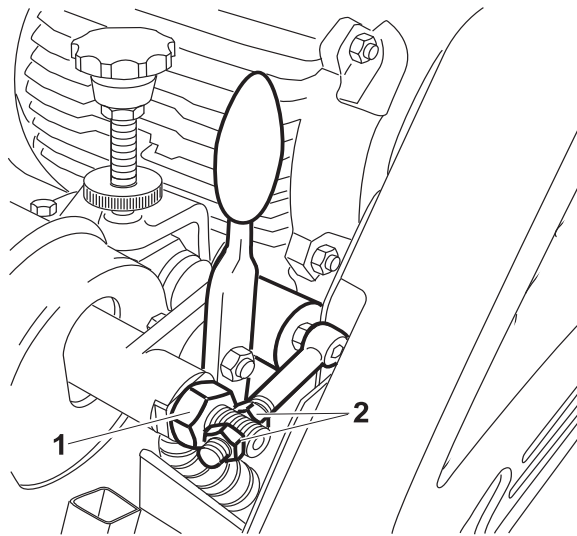

5. Loosen the retaining nut (1).
6. Connect the machine to the mains power (see chapter 7.7 and chapter 7.8).
7. Allow the machine to run in position "I".
8. By turning the adjusting nuts (2), you can move the tension roller to influence the path of the sanding belt. Adjust the position of the sanding belt until it runs in the middle of the sanding drum.
9. Switch the machine off.
10. Disconnect the machine from the mains power.
11. Tighten the adjusting nuts (2).
12. Tighten the retaining nut (1) securely.
13. Close the sanding drum cover.

8.5 Tightening the V-belts

If the V-belt tension has eased, adjustment must be made to achieve the proper tension. Whining or screeching are indications of insufficient V-belt tension.

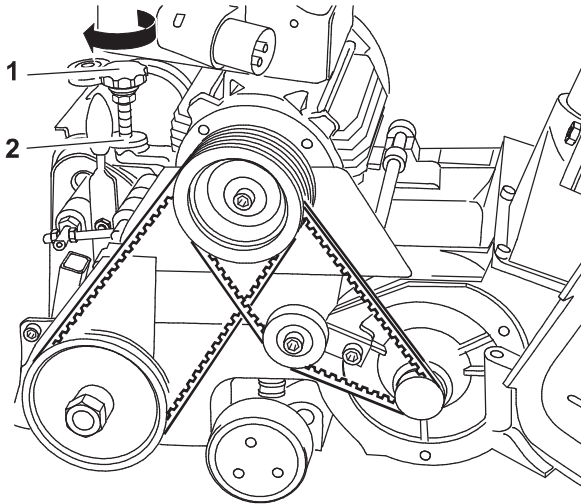

Instructions for tightening slack V-belts:

1. Switch the machine off.
2. Disconnect the machine from the mains power.
3. Unscrew the knurled nut on the belt guard and open the belt guard.
4. Loosen the lock nut (2) on the belt tension screw.
5. Turn the belt tension screw (1) clockwise until the V-belts are tight.
6. Tighten the lock nut (2).
7. Close the belt guard and screw the knurled nut back securely in place to secure the belt guard.



**Operating instructions
Parquet floor sander Python C 3,2kW/50Hz
with gentle lifting lever**

8.6 Guarantee

The guarantee period for new Frank machines is one year from the time of delivery/transfer to the customer, unless another period applies pursuant to mandatory legal regulations.

When making a claim under guarantee, the invoice and/or proof of purchase must be provided.

All repairs covered by the guarantee must be carried out by a Frank service shop recognised by us. Repairs which are carried out by the customer and/or improperly automatically lead to a disentanglement from guarantee claims. The same is true of improper operation and/or use.

Replacement of parts, accessories and other changes to Frank machines

Frank machines provide users with a high degree of safety and reliability. To maintain this, the condition of your Frank machine may not be changed from that on the date it was delivered from the factory without observing the following rules. These rules apply for the replacement of parts, the addition of accessories and other technical changes.

- All work done on your Frank machine must be carried out **exclusively by a specialist workshop** which has suitably trained and experienced staff and the working materials required. For this, we recommend an authorised Frank service shop.
- In the event that parts are deliberately replaced, accessories are deliberately added or other technical changes are deliberately carried out, the customer must always consult an authorised Frank service shop or us, the manufacturer, **before starting the work**.
- We urgently recommend only using safety-checked original Frank spare parts and original Frank accessories which have been cleared by us, the manufacturer. These spare parts and accessories can be purchased from your authorised Frank service shop, which will also be pleased to assemble them for you properly.

Original Frank spare parts and Frank accessories have been specially tested for their safety and suitability for Frank machines.

We can not sufficiently judge the safety and suitability of spare parts and accessories which are not original Frank parts, and are thus unable to vouch for them.

- To maintain operating reliability and avoid damage, in the case of technical changes – of whatever kind – our **technical guidelines are to be observed** in every case. Please also contact us at any other time if you have any questions about your Frank machine.

FRANK can not assume any liability for damages caused as a result of improper work and/or violation of the above terms and conditions.

Spare Parts
Floor sander Python C 3,2kW/50Hz
Item no 048666

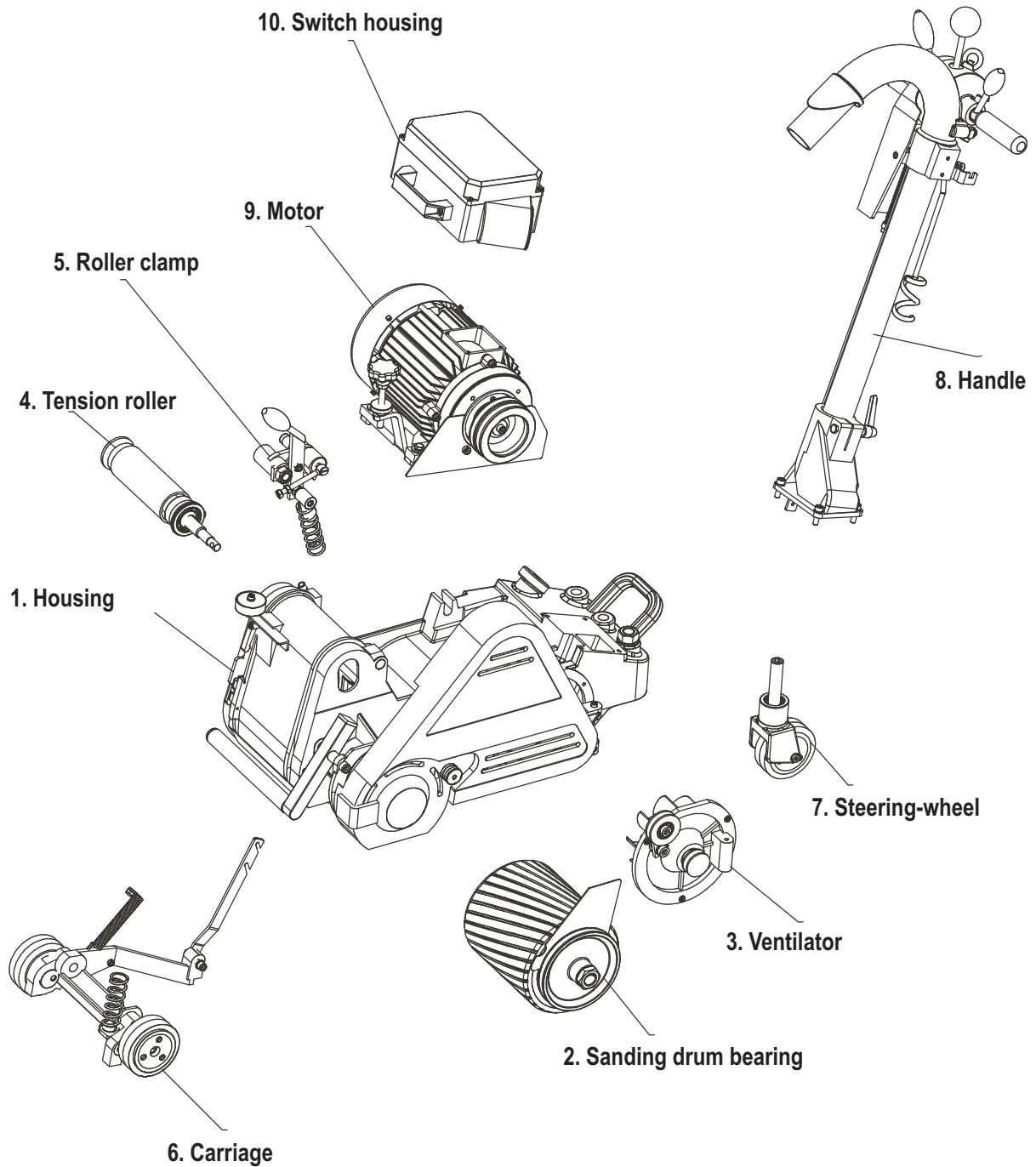

1. Housing: Python C 3,2kW/50Hz Item no 048666

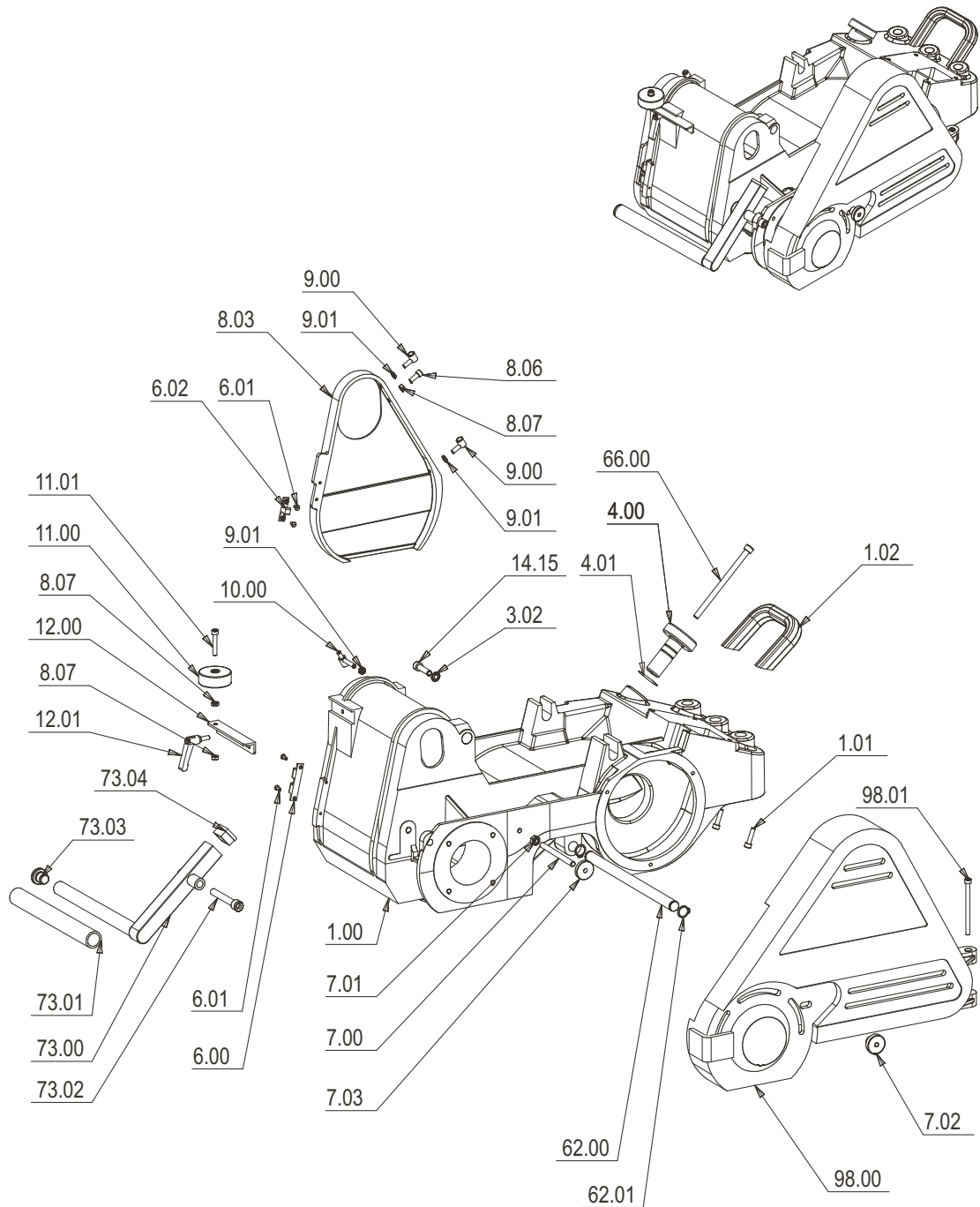

**Operating instructions
Parquet floor sander Python C 3,2kW/50Hz
with gentle lifting lever**



1. Housing: Python C 3,2kW/50Hz Item no 048666

Pos	Pcs	Ref	Description	Bezeichnung	Norm
1.00	1	043854	Machine chassis	Maschinengehäuse	
1.01	2	014731	Cylinder screw	Zylinderkopfschraube	DIN 912 - M6 x 25
1.02	1	048585	Handle	Griff	
3.02	1	016321	Serrated lock washer	Fächerscheibe	DIN 6798 - A 8,4
4.00	1	016327	Regulating screw	Druck-Regulier-Schraube	
4.01	1	043852	O-Ring red	Markierungsring rot	Ø 18 x 2,65
6.00	1	016328	Cover lock	Deckelschloss	
6.01	4	018323	Counter sunk screw	Senkschraube	DIN 963 - M4 x 8
6.02	1	016384	Lock notch	Schloss Raste	
7.00	1	016330	Stud bolt	Stiftschraube	DIN 835 - M8 x 85
7.01	1	014810	Hexagon nut	Sechskantmutter	DIN 934 - M8
7.02	1	016331	Knurled nut tall	Rändelmutter	DIN 466 - M8
7.03	1	018655	Knurled nut small	Rändelmutter	DIN 467 - M8
8.03	1	016176	Drum guard cover	Walzenschutz	
8.06	1	014729	Cylinder screw	Zylinderkopfschraube	DIN 912 - M6 x 16
8.07	3	014809	Hexagon nut	Sechskantmutter	DIN 934 - M6
9.00	2	016332	Cover hinges	Scharnier	
9.01	4	018666	Hexagon nut	Sechskantmuttern, dünn	ISO 4035 - M6
10.00	2	016334	Hood hinges	Scharnierbolzen	
11.00	1	016177	Bumper wheel	Anlaufgrad	
11.01	1	018264	Cylinder screw	Zylinderkopfschraube	DIN 912 - M6 x 35
12.00	1	016336	Bumper wheel support	Langloch-Winkeleisen	
12.01	1	047212	Clamp lever adjustable	Klemmhebel verstellbar	GN300-45-M6x16
14.15	1	014736	Cylinder screw	Zylinderkopfschraube	DIN 912 - M8 x 30
62.00	1	043829	Main axle	Fahrwerkachse	
62.01	2	043891	Outer packing ring	Sicherungsringe für Wellen	DIN 471 - 16x1
66.00	1	016432	Cylinder screw	Zylinderschraube	DIN 912-M8x130
73.00	1	043899	Carry handle	Tragebügel	
73.01	1	043846	Handle covering	Kunststoffbezug	
73.02	1	016441	Cylinder screw	Zylinderkopfschraube	DIN 912 - M10 x 75
73.03	1	016442	Plastic closing	Verschlussstopfen	
73.04	1	019118	Plastic closing	Vierkantstopfen	
98.00	1	016456	Belt guard	Riemenschutzhaube	
98.01	1	016457	Cylinder screw	Zylinderschraube	DIN 912 - M6 x 85

2. Sanding drum bearing: Python C 3,2kW/50Hz Item no 048666

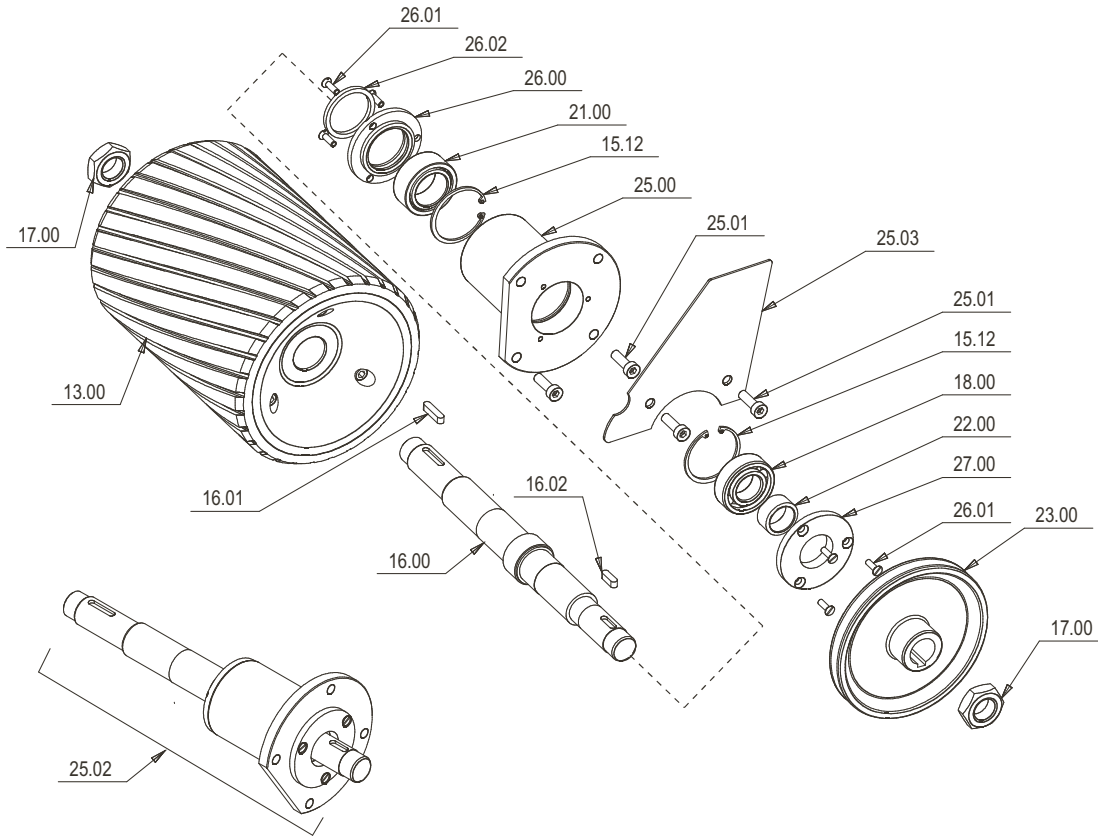

Pos	Pcs	Ref	Description	Bezeichnung	Norm
13.00	1	043879	Drum COBRA	Schleifwalze gummiert COBRA	KING COBRA 10" (250mm)
15.12	2	014857	Lock ring	Sicherungsringe für Bohrungen	DIN 472 - 52x2
16.00	1	043880	Drum shaft COBRA	Schleifwalzenwelle COBRA	KING COBRA 10" (250mm)
16.01	1	016361	Parallel key	Paßfeder	DIN 6885 - A 6 x 6 x 30
16.02	1	016362	Parallel key	Paßfeder	DIN 6885 - A 6 x 6 x 20
17.00	2	014614	Hexagon nut	Sechskantmuttern, dünn	ISO 4035 - M24x1,5
18.00	1	018348	Ball bearings	Rillenkugellager	DIN 625 T1 - 6205 - 25 x 52 x 15
21.00	1	016183	Needle bearing	Nadellager mit Führungflanschen	DIN 617 SKF - SKF NA 49/32
22.00	1	016184	Spacer	Distanzbuchse	
23.00	1	016185	Drum pulley	Walzen-Riemenscheibe	
25.00	1	016364	Drum bearing flange	Walzenlagerflansch	
25.01	4	016365	Cylinder screw	Zylinderkopfschraube	DIN 6912 - M8 x 25
25.02	1	048046	Drum flange complete	Walzenlagerflansch komplett	PYTHON C
26.00	1	016366	Inner drum cover	Lagerdeckel innen	
26.01	6	016701	Counter sunk screw	Senkschraube	DIN 963 - M5 x 16
26.02	1	016188	Felt packing strip	Filzdichtring	
27.00	1	016368	Outer drum cover	Lagerdeckel aussen	
98.03	1	016458	V-belt guard	Schutzblech	

3. Ventilator: Python C 3,2kW/50Hz Item no 048666

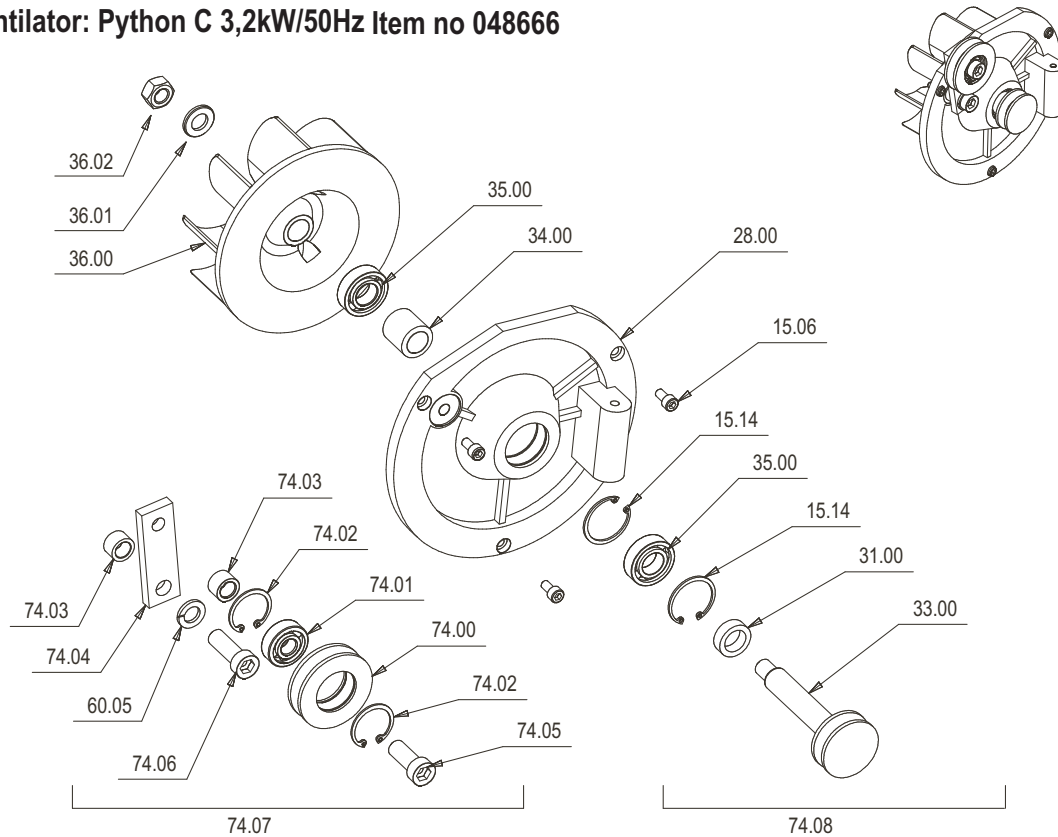

Pos	Pcs	Ref	Description	Bezeichnung	Norm
15.06	3	014726	Cylinder screw	Zylinderkopfschraube	DIN 912 - M6 x 12
15.14	2	018091	Locking ring	Sicherungsringe für Bohrungen	DIN 472 - 35x1,5
28.00	1	016369	Fan flange	Ventilatorflansch	
31.00	1	016372	Spacer	Distanzring	25x17x8
33.00	1	014597	Fan Shaft	Ventilatorwelle	
34.00	1	016374	Spacer	Distanzbuchse	
35.00	2	018359	Ball bearings	Rillenkugellager	DIN 625 T1 - 6003 - 17 x 35 x 10
36.00	1	043907	Fan	Ventilatorrad	
36.01	1	014830	Washer	Scheibe	DIN 125-1 - B 13
36.02	1	018663	Hexagon nut	Sechskantmutter	DIN 934 - M12
60.05	1	016424	Circlip	Federring	DIN 127 - A 12
74.00	1	016443	Tension ring	Spannrollenring	
74.01	1	018352	Ball bearings	Rillenkugellager	DIN 625 T1 - 6201 - 12 x 32 x 10
74.02	2	014854	Outer packing ring	Sicherungsring	DIN 472 - 32 x 1,2
74.03	2	016446	Spacer	Distanzbuchse	
74.04	1	016447	v-belt tens holder	Spannrollenhalter	
74.05	1	016448	Cylinder screw	Zylinderkopfschraube	DIN 6912 - M12 x 30
74.06	1	016449	Cylinder screw	Zylinderkopfschraube	DIN 6912 - M12 x 35
74.07	1	048691	Tensioner complete	Spannrolle komplett	
74.08	1	048033	Ventilatorflange complete	Ventilatorflansch komplett	PYTHON C



Operating instructions
Parquet floor sander Python C 3,2kW/50Hz
with gentle lifting lever

4. Tension roller:
Python C 3,2kW/50Hz
Item no 048666

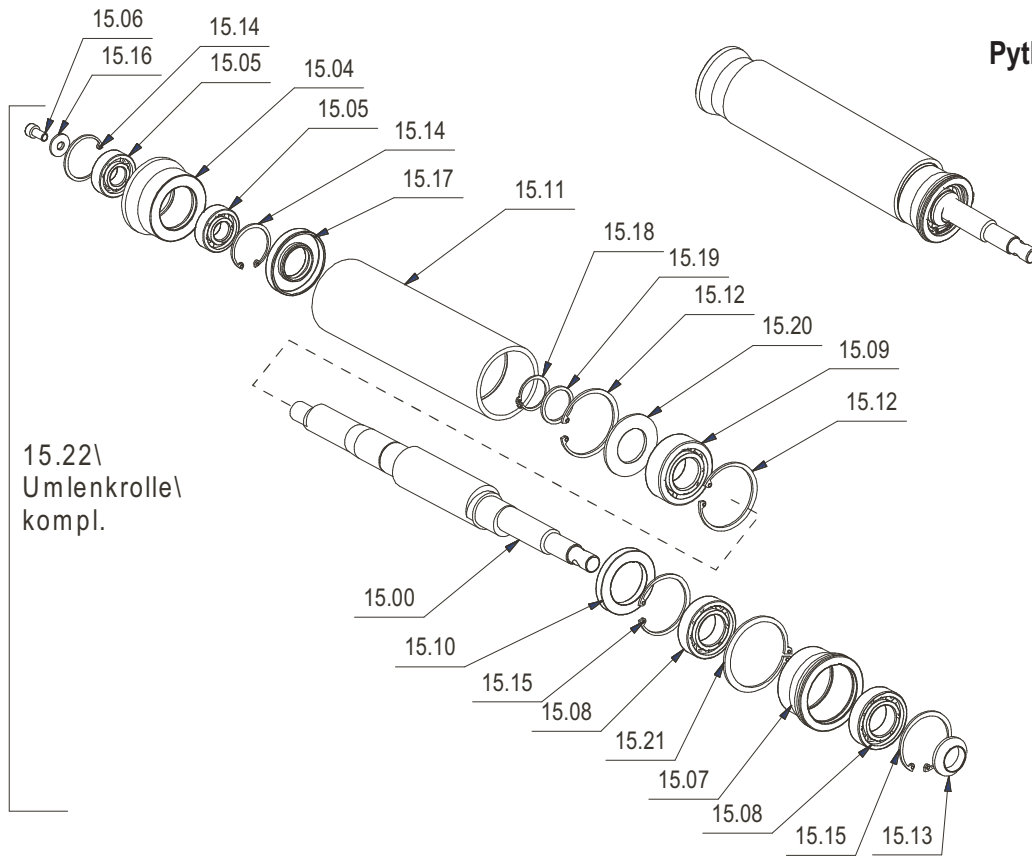

Pos	Pcs	art. no	Description	Bezeichnung	Werkstoff/Norm
15.00	1	043904	Tension roller shaft COBRA	Umlenkrollen-Welle COBRA	10" (250 mm)
15.04	1	014622	External roller	Aussenrolle	
15.05	2	018351	Ball bearing	Rillenkugellager	DIN 625 15 x 35 x 11
15.06	1	014726	Cylinder screw	Zylinderkopfschraube	DIN 912 - M6 x 12
15.07	1	014625	Inner roll empty	Innenrolle	014625
15.08	2	014704	Ball bearings	Rillenkugellager	DIN 625 25 x 47 x 12
15.09	1	016198	Swivel bearing	Pendelkugellager	DIN 630 - 2205 - 25 x 52 x 18
15.10	1	014628	Shaft sealing ring	Wellendichtring	DIN 3760 35 x 52 x 7 NBR
15.11	1	043848	Roller	Laufrolle	10" (250 mm)
15.12	2	014857	Lock ring	Sicherungsring	DIN 472 - 52x2
15.13	1	016202	Adjustment ring	Justiering	
15.14	2	018091	Locking ring	Sicherungsring	DIN 472 - 35x1,5
15.15	2	014855	Locking ring	Sicherungsring	DIN 472 - 47x1,75
15.16	1	017724	Washer	Scheibe	DIN 9021 - 6,4
15.17	1	014634	Shaft sealing ring	Wellendichtring	DIN 3760 25 x 52 x 7
15.18	1	014852	Locking ring	Sicherungsringe für Wellen	DIN 471 - 25x1,2
15.19	1	016360	Compens. washer	Stützscheibe	DIN 988 - S25 x 35
15.20	1	043833	Lock washer	Gewellte Federscheibe	DIN 137 - B27
15.21	1	043894	Looking ring	Sicherungsringe für Wellen	DIN 471 - A60
15.22	1	048081	Tension roller complete	Umlenkrolle komplett	10" (250 mm)

5. Roller clamp: Python C 3,2kW/50Hz Item no 048666

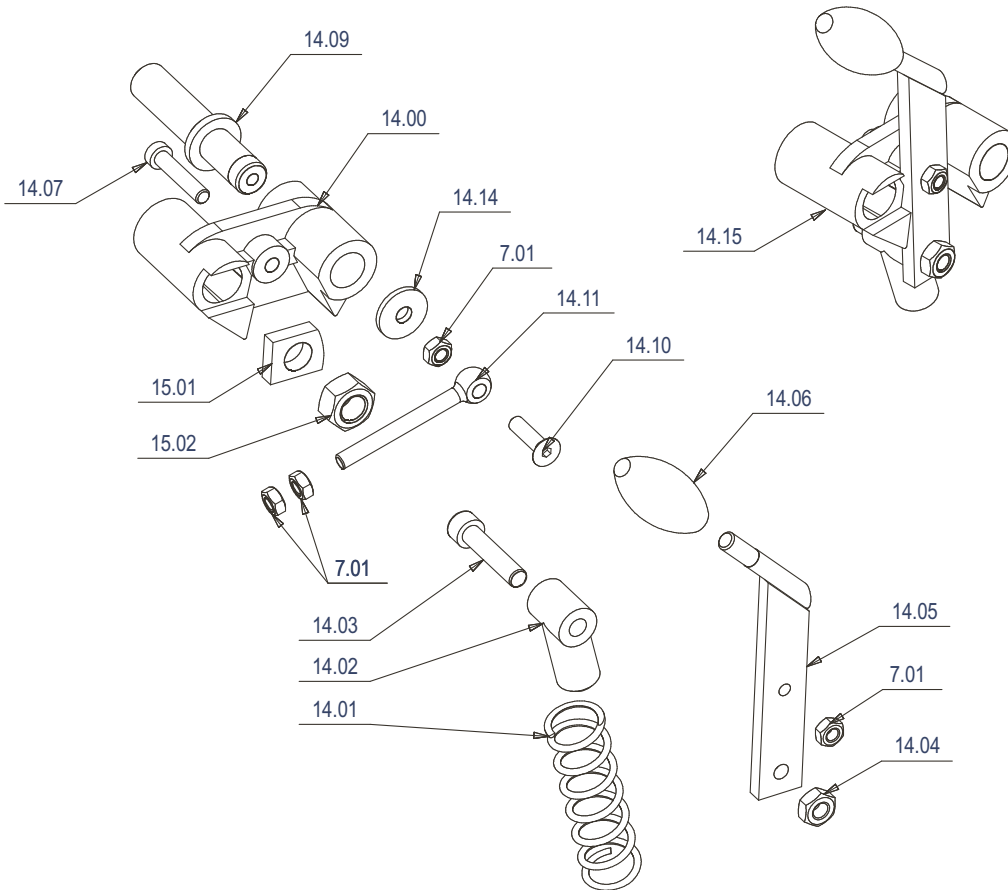

Pos	Pcs	Ref	Description	Bezeichnung	Werkstoff/Norm
7.01	4	014810	Hexagon nut	Sechskantmutter	DIN 934 - M8
14.00	1	016338	Tension lever	Spannwalzenhalter	
14.01	1	016179	Pressure spring	Druckfeder	
14.02	1	016492	Pressure pad	Druckstück	
14.03	1	016340	Cylinder screw	Zylinderkopfschraube	DIN 6912 - M10
14.04	1	014811	Hexagon nut	Sechskantmutter	DIN 934 - M10
14.05	1	016342	Tension lever	Spannhebel	
14.06	1	016180	Handle grip	Ballengriff	
14.07	1	016343	Cylinder screw	Zylinderkopfschraube	DIN 6912 - M8 x 45
14.09	1	016345	Mounting bolt	Haltebolzen	
14.10	1	017116	Countersink screw	Senkschraube	DIN 963 - M8 x 30
14.11	1	016347	Eye screw	Ringschraube	DIN 444 - A - M8 x 80
14.14	1	043902	Washer	Unterlegscheiben	DIN 522 - 8,4 x 30
14.15	1	048500	Trnsion lever compl.	Spannwalzenhalter komplett	
15.01	1	016190	Adjusting plate	Führungsplatte	
15.02	1	014620	Hexagon nut	Sechskantmutter	DIN 934 - M16

6. Carriage: Python C 3,2kW/50Hz
Item no 048666

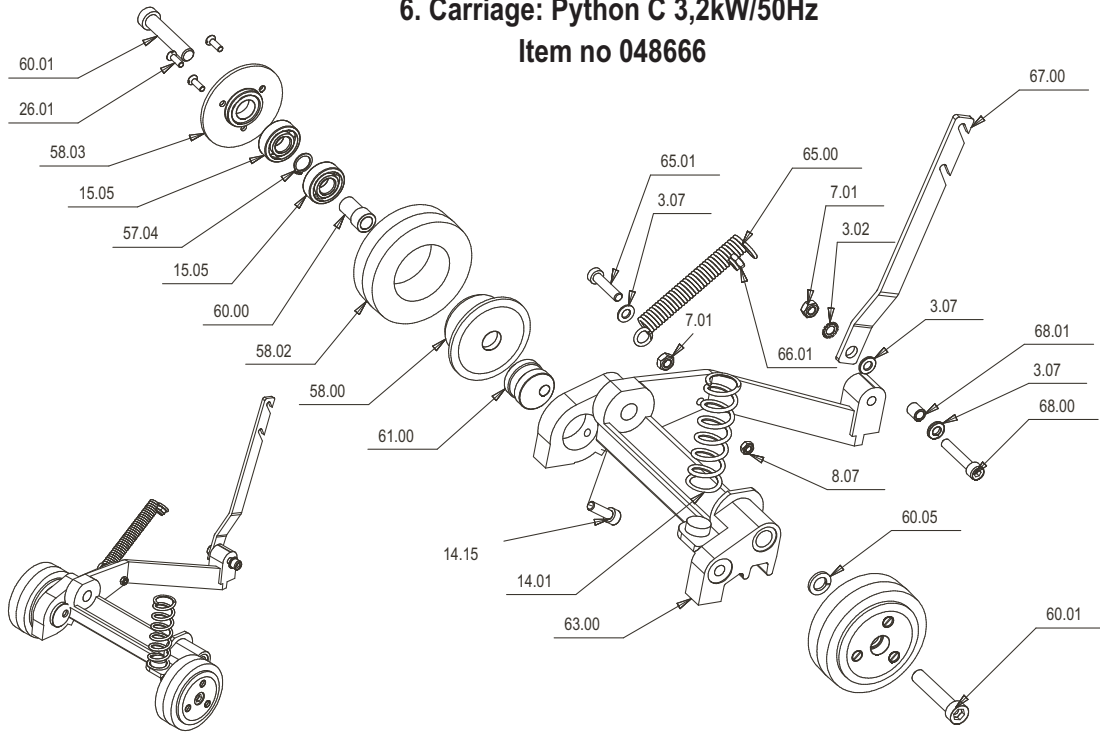

Pos	Pcs	Ref	Description	Bezeichnung	Werkstoff/Norm
3.02	1	016321	Serrated lock washer	Fächerscheibe	DIN 6798 - A 8,4
3.07	3	014828	Washer	Scheibe	DIN 125-1 - B 8,4
7.01	2	014810	Hexagon nut	Sechskantmutter	DIN 934 - M8
8.07	1	014809	Hexagon nut	Sechskantmutter	DIN 934 - M6
14.01	1	016179	Pressure spring	Druckfeder	
14.15	1	014735	Cylinder screw	Zylinderkopfschraube	DIN 912 - M8 x 25
15.05	4	018351	ball bearing	Rillenkugellager	DIN 625 15 x 35 x 11
26.01	6	016701	Counter sunk screw	Senkschraube	DIN 963 - M5 x 16
57.04	2	018101	Outer packing ring	Sicherungsringe für Wellen	DIN 471 - 15x1
58.00	2	016415	Caster wheel felloe	Lauf- u. Lenkradfelge	
58.02	2	016171	Vulkollan-shoe	Vulkolanbelag	
58.03	2	016416	felloe cover	Felgendeckel	
59.06	1	037082	Running wheel complete	Laufrad komplett	
60.00	1	016422	Running wheel bushing	Laufradbuchse	
60.01	2	016554	Cylinder screw	Zylinderkopfschraube	DIN 6912 - M12 x 55
60.05	1	016424	Circlip	Federring	DIN 127 - A 12
61.00	1	016425	Excentric	Exzenter	
63.00	1	043828	Running wheel bracket	Fahrwerkhebel	
65.00	1	016175	Reg. Spring	Zugfeder	
65.01	1	016430	Cylinder screw	Zylinderkopfschraube	DIN 6912 - M8 x 35
66.01	1	014816	Hexagon nut	Sechskantmutter	DIN 985 - M8
67.00	1	043914	Control rod connector	Zugstangen-Verbindung	
68.00	1	016739	Cylinder screw	Zylinderkopfschraube	DIN 912 - M8 x 45
68.01	1	016437	Spacer	Distanzbuchse 68.01	11x8x5

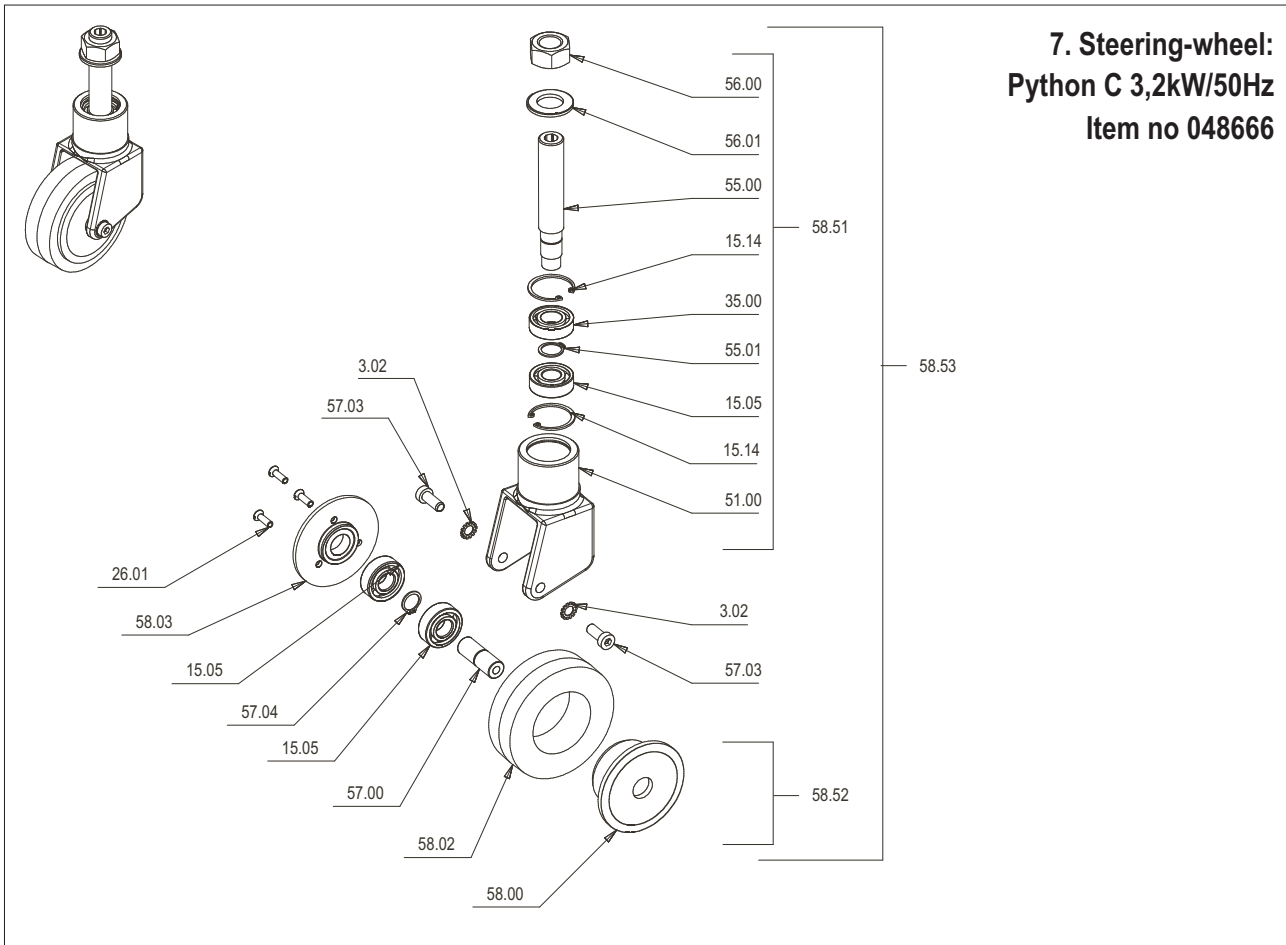

7. Steering-wheel:
Python C 3,2kW/50Hz
Item no 048666

Pos	Pcs	Ref	Description	Bezeichnung	Norm
3.02	2	016321	Serrated lock washer	Fächerscheibe	DIN 6798 - A 8,4
15.05	3	018351	Ball bearing	Rillenkugellager	DIN 625 T1 - 6202 - 15 x 35 x 11
15.14	2	018091	Locking ring	Sicherungsringe für Bohrungen	DIN 472 - 35x1,5
26.01	3	016701	Counter sunk screw	Senkschraube	DIN 963 - M5 x 16
35.00	1	018359	Ball bearings	Rillenkugellager	DIN 625 T1 - 6003 - 17 x 35 x 10
51.00	1	016406	Steering-wheel fork	Lenkrollengabel	
55.00	1	016410	Bushing axle	Schwenkachse	
55.01	1	014850	Outer packing ring	Sicherungsringe für Wellen	DIN 471 - 17x1
56.00	1	039981	Hexagon nut	Sechskantmutter	DIN 934 - M20
56.01	1	039982	Washer	Scheibe	DIN 125-1 - B 21
57.00	1	014601	Caster wheel axle	Lenkrad-Achse	
57.03	2	016413	Cylinder screw	Zylinderkopfschraube	DIN 6912 - M8 x 20
57.04	1	018101	Outer packing ring	Sicherungsringe für Wellen	DIN 471 - 15x1
58.00	1	016415	Caster wheel fell.	Lauf- u. Lenkradfelge	
58.02	1	016171	Vulkolan-shoe	Vulkolanbelag	
58.03	1	016416	Felloe cover	Felgendeckel	
58.51	1	047064	Steering-wheel fork compl.	Lenkradgabel komplett	
58.52	1	016380	Wheel compl.	Rolle komplett	
58.53	1	016380	Steering wheel compl.	Lenkrolle komplett	



Operating instructions
Parquet floor sander Python C 3,2kW/50Hz
with gentle lifting lever

8. Handle: Python C 3,2kW/50Hz Item no 048666

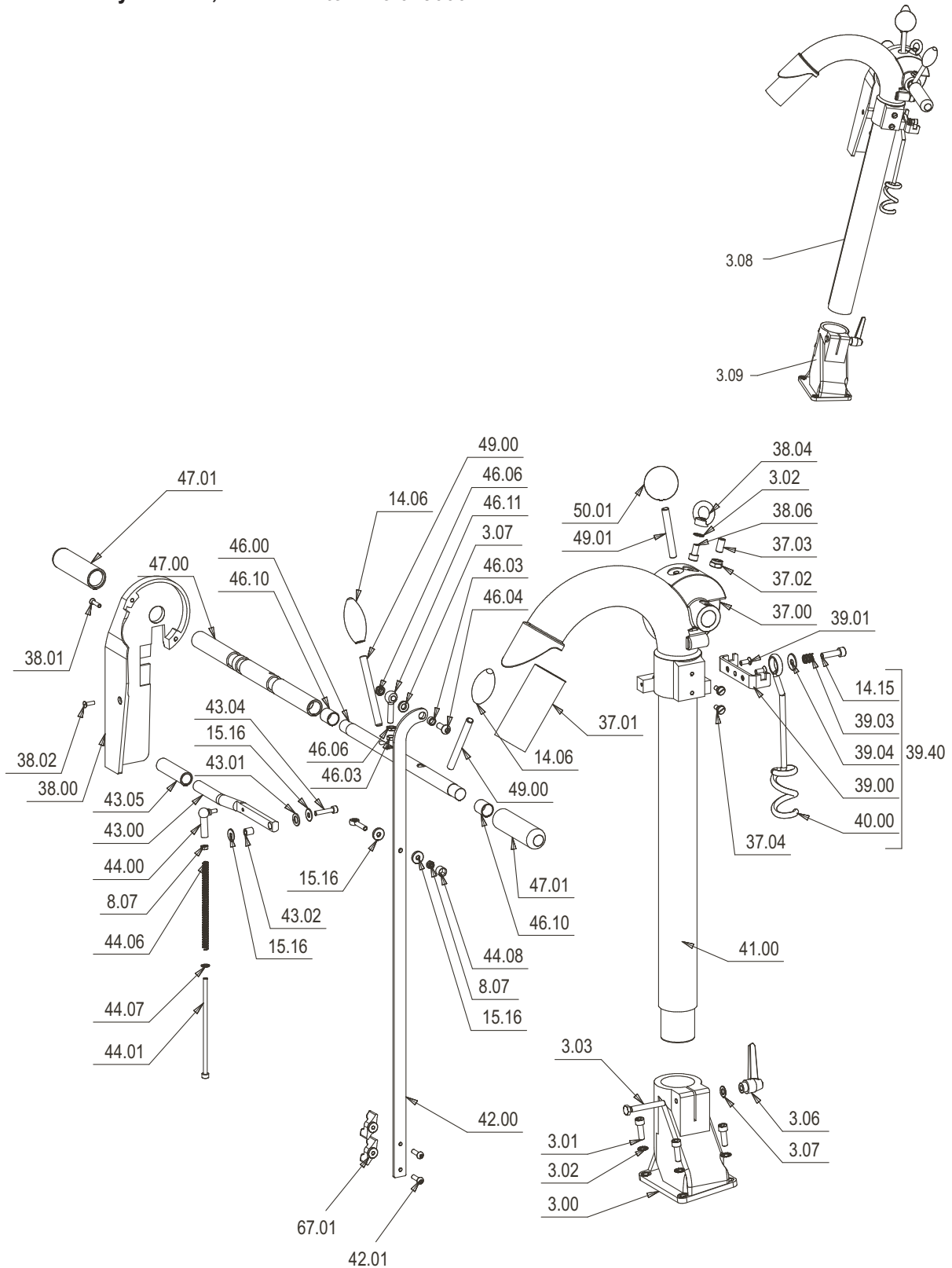

Operating instructions
Parquet floor sander Python C 3,2kW/50Hz
with gentle lifting lever



8. Handle: Python C 3,2kW/50Hz Item no 048666

Pos	Pcs	Ref	Description	Bezeichnung	Norm
3.00	1	047307	Dust pipe support	Staub-/Lenkrohrhalter	
3.01	4	014735	Cylinder screw	Zylinderkopfschraube	DIN 912 - M8 x 25
3.02	5	016321	Serrated lock washer	Fächerscheibe	DIN 6798 - A 8,4
3.03	1	047213	Hexagon screw	Sechskantschraube	DIN 933 - M8 x 60
3.06	1	047121	Clamping lever	Klemmhebel verstellbar	M8
3.07	2	014828	Washer	Scheibe	DIN 125-1 - B 8,4
3.08	1	048625	Steering compl.	Lenkung kompl. (595)	
3.09	1	048702	Dust pipe support compl.	Lenkerfuß kompl.	
8.07	2	014809	Hexagon nut	Sechskantmutter	DIN 934 - M6
14.06	2	016180	Handle grip	Ballengriff	
14.15	1	014736	Cylinder screw	Zylinderkopfschraube	DIN 912 - M8 x 30
15.16	4	017724	Washer	Scheibe	DIN 9021 - 6,4
37.00	1	043815	Steering head	Lenkerkopf	
37.01	1	047208	Connecting piece	Absaugstutzen	
37.02	1	014817	Hexagon nut	Sechskantmutter	DIN 985 - M10
37.03	1	018216	Headless pin	Gewindestift	DIN 913 - M10 x 20
37.04	2	014808	Flat head screw	Flachkopfschraube	DIN 923 - M6 x 5
38.00	1	016615	Steering head cover	Gehäuseabdeckung	
38.01	2	017727	Counter sunk screw	Senkschrauben mit Innensechskant	DIN 7991 - M5x20
38.02	1	016312	Counter sunk screw	Senkschrauben mit Innensechskant	DIN 7991 - M5x16
38.04	1	016618	Ring nut	Ringmuttern	DIN 582 - M8
38.06	1	017651	Cylinder screw	Zylinderkopfschraube	DIN 912 - M8 x 16
39.00	1	016521	Pier for cable clip	Kabelhalterstütze	
39.01	2	043888	Counter sunk screw	Senkschrauben mit Innensechskant	DIN 7991 - M6x16
39.03	1	043827	Pressure spring	Druckfeder	
39.04	1	018737	Washer	Scheibe	DIN 9021 - 8,4
40.00	1	014548	Cable arm	Kabelhalterarm	
41.00	1	047308	Dust pipe	Staubrohr	
42.00	1	047303	Contr. rod	Zugstange	
43.00	1	016628	Drum lifting grip	Abhebegriff	
43.01	1	043831	Circlip	Federring	DIN 128 - A10
43.02	1	016629	Spacer	Distanzbüchse	
43.04	1	017678	Cylinder screw	Zylinderkopfschraube	DIN 912 - M6 x 30
43.05	1	043838	Shrinking hose	Schrumpfschlauch	
44.00	1	016632	Angle joint	Winkelgelenk	
44.01	1	016633	Cylinder screw	Zylinderschraube	DIN 912 - M6 x 150
44.03	1	016635	Ring bolt	Ringschraube	DIN 444 - A - M6 x 35
44.06	1	016638	Pressure spring	Druckfeder	
44.07	1	014827	Washer	Scheibe	DIN 125-1 - B 6,4
44.08	1	043882	Guard cover	Schutzkappe	
46.00	1	047304	Axle	Welle f. Absenkung	
46.03	2	016396	Spacer	Distanzbüchse	
46.04	1	047385	Rounded head screw	Linienflanschkopfschraube	ISO 7380 - M8 x 20
46.05	1	036222	Adjusting washer	Stützscheibe	DIN 988 - S12 x 18
46.06	2	017676	Hexagon nut	Sechskantmutter, dünn	ISO 4035 - M8
46.10	2	047218	Bushing	DU Buchse	
46.11	1	047216	Ring bolt	Ringschraube	DIN 444 - A - M8 x 40
47.00	1	047301	Handlehold	Griffrohr	
47.01	2	047310	Grip covering	Griffbezug	
49.00	2	047214	Stud bolt	Stiftschraube	DIN 835 - M10 x 80
49.01	1	014788	Stud bolt	Stiftschraube	DIN 835 - M10 x 60
50.01	1	047220	Ball handle	Kugelknopf	
67.01	2	047796	Wing nut	Flügelmutter	

9. Motor: Python C 3,2kW/50Hz Item no 048666

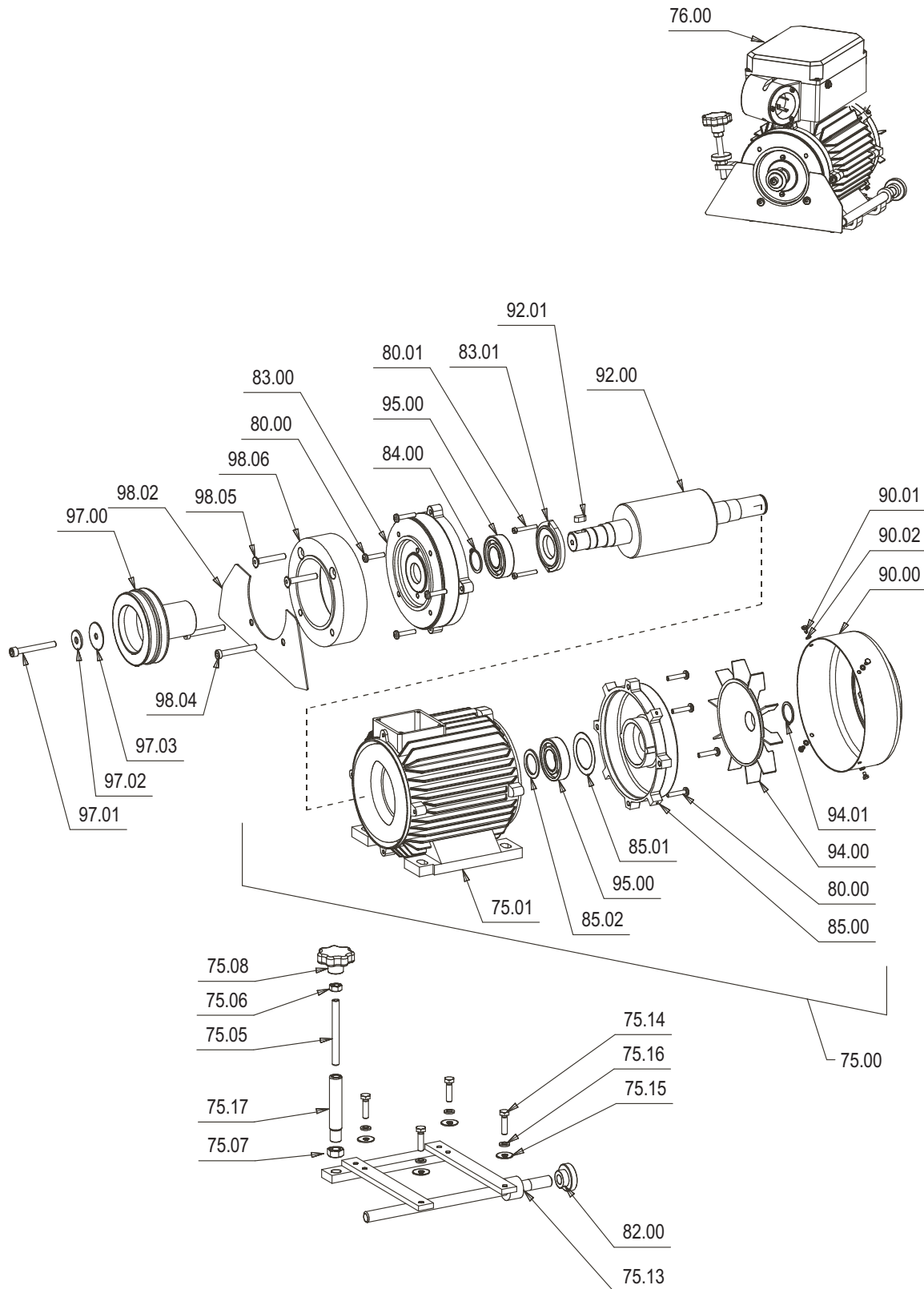



9. Motor: Python C 3,2kW/50Hz Item no 048666

Pos	Pcs	Ref	Bezeichnung	Description	Werkstoff/Norm
75.00	1	048530	Motor	Motor	3,2 kW/50Hz
75.01	1		Chassis Motor	Motorgehäuse m. Stator	3,2 kW/50Hz
75.05	1	048059	Thread rod	Gewindestange	M 10x200
75.06	1	017667	Hexagon nut	Sechskantmutter	DIN 936 - M10
75.07	1	043834	Flat knurled nut	Rändelmutter	DIN 467 - M10
75.08	1	043897	Star grip	Sterngriff	M10
75.13	1	043858	Motor base	Motorsockel	
75.14	4	017060	Hexagon bolt	Sechskantschraube	DIN 933 - M8 x 30
75.15	4	018737	Washer	Unterlegscheibe	DIN 9021 - 8,4
75.16	4	016455	Circlip	Federring	DIN 127 - A 8
75.17	1	043857	Tube motor base	Motorsockel Rohrstück	
76.00	1	048656	Motor complete PYTHON	Motor komplett PYTHON	3,2 kW/50Hz
80.00	8	043836	Winding screw	Gewindefurchende Schraube	DIN 7500 M6 x 30
80.01	2	043920	Cylinder screw	Zylinderschraube mit Schlitz	DIN 84 - M5 x 35
82.00	1	016603	Knurled nut	Rändelmutter	M16
83.00	1	043909	Front bearing cover	Vorderes Lagerschild	
83.01	1	043847	Bearing cover	Lagerdeckel	
84.00	1	014853	Outer packing ring	Sicherungsringe für Wellen	DIN 471 - 30x1,5
85.00	1	043840	Rear bearing cover	hinteres Lagerschild	
85.01	1	043913	Ring	Wellenring	
85.02	1	043824	Spacer	Distanzscheibe	
90.00	1	043906	Fan cover	Ventilatorhaube	
90.01	4	043887	Hexagon screw	Sechskantschraube	DIN 933 - M4 x 6
90.02	4	043830	Circlip	Federring	DIN 127 - A 4
92.00	1		Rotor with axle	Rotor m. Welle	3,2 kW/50Hz
92.01	1	043862	Drum parallel key	Paßfeder	DIN 6885 - A 8 x 7 x 14
94.00	1	043860	Motor fan	Motorventilator	
94.01	1	043893	Outer packing ring	Sicherungsringe für Wellen	DIN 471 - 28x1,5
95.00	2	043845	Ball bearing	Kugellager, einreihig	6206-2RS
97.00	1	043856	Motor pulley	Motorriemenscheibe	
97.01	1	018251	Cylinder screw	Zylinderkopfschraube	DIN 912 - M8 x 65
97.02	1	016612	Washer	U-Scheibe	DIN 440-9
97.03	1	043903	Washer	U-Scheibe	DIN 522-8,4 x 40x2
98.02	1	043884	v-belt guard	Schutzblech	
98.04	2	043917	Cylinder screw	Zylinderkopfschraube	DIN 7984 - M8 x 55
98.05	2	017631	Counter sunk screw	Senkschraube	DIN 7997 - M8 x 50
98.06	1	043821	Spacer	Distanzring	
100.00	1	043910	drum V-belt	Walzen Keilriemen	XPZ 962
101.00	1	014596	fan V-belt	Ventilator Keilriemen	X10x732

10. Switch housing:
Python C 3,2kW/50Hz
Item no 048666

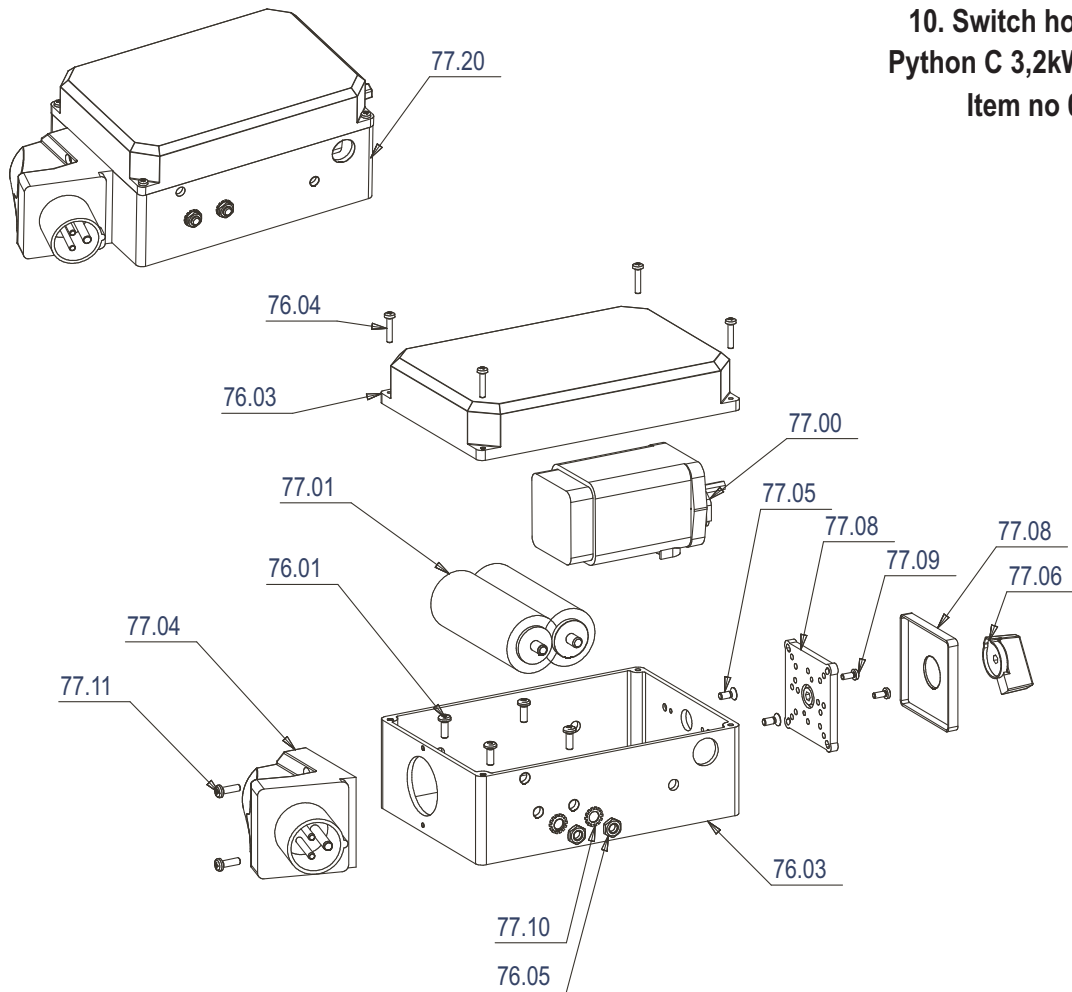

Pos	Pcs	Ref	Description	Bezeichnung	Werkstoff/Norm
76.01	4	049052	Thread-rolling screw	Gewindefurchende Schraube	DIN 7500 - M5 x 16 - 4.8 - Z
76.03	1	048534	Switch housing	Schalterkasten	
76.04	4	014805	Raised-head screw	Linsenschraube	DIN 7985 (H) - M4x20-H
76.05	2	017676	Hexagon nut	Sechskantmuttern	DIN 936 - M8
77.00	1	049068	Switch	Schalter	
77.01	2	043843	Capacitor 60 µF	Kondensator 60 µF	
77.04	1	043911	Connector 16A	Einbaustecker CEE 16A	
77.05	2	043890	Counter sunk screw	Senkschraube	DIN 965 - M5 x 12
77.06	1	043875	Switch toggle	Schalterknebel	
77.08	1	043877	Position label	BG Schalterpositionsschild	
77.09	2	043851	Raised-head screw	Linsenschrauben	DIN 7985 - M4x10
77.10	2	016321	Serrated lock washer	Fächerscheibe	DIN 6798 - A 8,4
77.11	2	049052	Thread-rolling screw	Gewindefurchende Schraube	DIN 7500 - M5 x 16 - 4.8 - Z
77.20	1	048639	Switch housing compl.	Schalterkasten kompl.	

Operating instructions
Parquet floor sander PYTHON C 3,2kW/50Hz
with gentle lifting lever



Accessories:
Python C 3,2kW/50Hz
Item no 048666

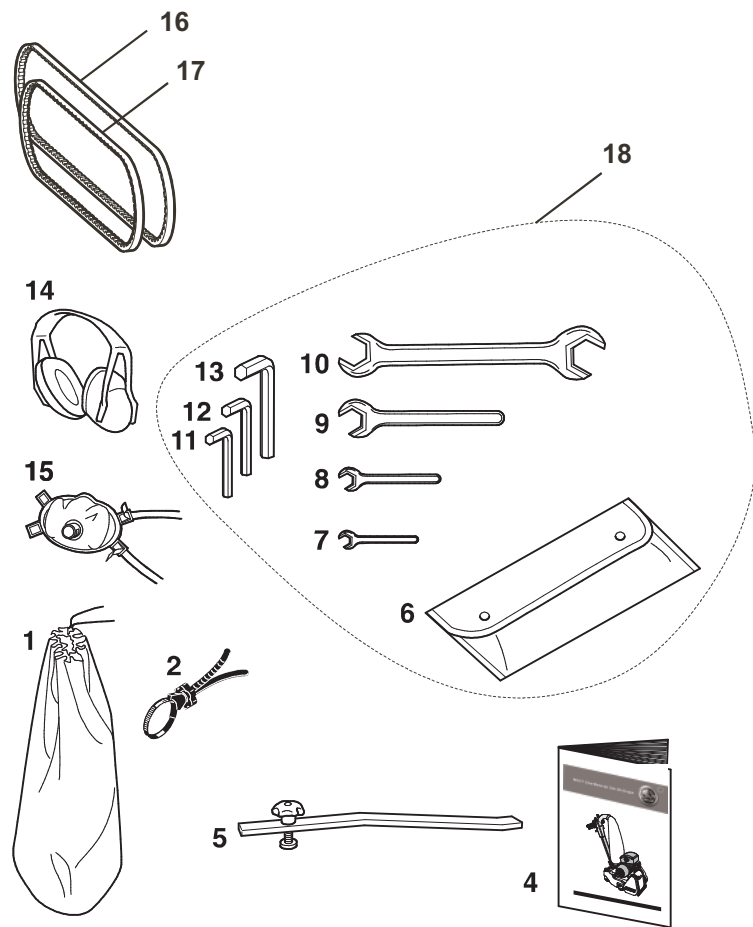

Pos	Ref	Description	Bezeichnung
1	013839	dust bag	Staubsack
2	016813	Multiclip	Multiclip
3	048641	cabale with plug and coupling	Netzkabel mit Stecker und Kupplung
4	049275	operating instructions	Bedienungsanleitung
5	048655	running wheel adjusting tool	Laufrollen-Einstellgerät
6	016459	tool pouch, empty	Werkzeugtasche, leer
7	016842	fork wrench 10 mm	Einmaulschlüssel 10 mm
8	016799	fork wrench 13 mm	Einmaulschlüssel 13 mm
9	018635	fork wrench 24 mm	Einmaulschlüssel 24 mm
10	043825	double fork wrench 30/36 mm	Doppelmaulschlüssel 30/36 mm
11	014956	hexagon socket screw key 5 mm	Sechskant-Schraubendreher 5 mm
12	014957	hexagon socket screw key 6 mm	Sechskant-Schraubendreher 6 mm
13	018641	hexagon socket screw key 10 mm	Sechskant-Schraubendreher 10 mm
14	015315	hearing protectors	Kapselgehörschutz
15	016732	respirator	Atenschutzmaske
16	043910	drum V-belt XPZ 962	Walzen Keilriemen XPZ 962
17	014596	fan V-belt X10x732	Ventilator Keilriemen X10x732
18	016357	Tool kit complete	Werkzeugsatz komplett



Operating instructions
Parquet floor sander Python C 3,2kW/50Hz
with gentle lifting lever

Wiring diagram: Python C 3,2kW/50Hz
Item no 048666

